

MINI EOLO 3 E

***Compact wall-hung
instantaneous boilers
with sealed-chamber***

MINI EOLO X 3 E

***Compact wall-hung boiler with
sealed-chamber for central
heating only or with an external
storage tank***



MINI EOLO 24-28 3 E



Small wall-mounted instant boiler with sealed chamber (type C) and fan-assisted circulation

MINI EOLO 24 3 E

MINI EOLO 28 3 E

General features

MINI EOLO 3 E is a wall-mounted, sealed chamber, fan-assisted generator (type C) for central heating and the production of domestic hot water.

The boiler can be installed according to configuration B₂₂ using the relevant kit (*optional*).

The boilers in the MINI EOLO 3 E range are approved for installation outside buildings in a partially protected location.

N.B.: *a partially protected location is a place where the appliance is not exposed to the direct effects of the weather (rain, snow, hail, etc..).*

The appliance is available with effective outputs of 24 kW (20.640 kcal/h), 28 kW (24.080 kcal/h).

Adjustment and control are entrusted to an integrated P.C.B. with micro processor with continuous flame modulation by means of 2 sensors (*domestic water and central heating*).

The new electronics allow the connection of the appliance to the New Comando Amico Remoto (CAR ^{v2}) and allow to manage and control the boiler at a distance with great ease.

The boiler has a **standard anti-freeze safety device** that protects it to a minimum temperature of **-5°C** (*optional to -15°C*).

The hydraulic circuit has a bronze water-gas heat exchanger and uses a new multi-purpose hydraulic unit made from composite material (ICHS) which houses the pump and 3-way electric valve that allow the boiler water to circulate in the CH system or in a STAINLESS steel plate heat exchanger

for the instantaneous production of DHW according to necessity, as well as the hydraulic circuit control devices (*absolute system pressure switch, adjustable system by-pass, 3-bar calibrated system safety valve, etc...*).

A domestic water flow switch allows the boiler to be activated when domestic hot water is requested.

The boiler is designed to receive pre-heated water from a solar storage tank; by activating this function through the boiler parameters, the burner and the boiler turn on only if necessary in order to reach the set domestic hot water set point.

The intake of combustion air inside the sealed chamber and flue extraction are ensured by a fan which is guaranteed to operate correctly by means of a differential flue pressure switch.

The parameters to operate the boiler can be set via the buttons, where you can view the operating status, mode and anomalies that have occurred using a digital interface with an easy-to-read backlit display screen, located in the centre of the dashboard.

The appliance has an IPX5D electric insulation rating; this means that the boiler is protected against jets of water and high humidity levels.

MINI EOLO X 24 3 E



Wall-mounted boiler with sealed, fan-assisted combustion chamber, heating only and which can be combined with an external Storage tank unit

MINI EOLO X 24 3 E

General features

MINI EOLO X 24 3 E is a wall-mounted, fan-assisted generator with sealed chamber (type C), heating only. Thanks to a special kit (*optional*), it is designed to be combined with a separate 80, 105, 120, 200 and 300 litre Storage tank unit. The boiler can be installed according to configuration B₂₂ using the relevant kit (*optional*).

The boilers in the MINI EOLO X 24 3 E range are approved for installation outside buildings in a partially protected location.

N.B.: *a partially protected location is a place where the appliance is not exposed to the direct effects of the weather (rain, snow, hail, etc.).*

The appliance is available with effective outputs of 24 kW (20.640 kcal/h).

The adjustment and the control of the appliance are entrusted to a microprocessor-integrated P.C.B. with continuous flame modulation.

The new electronics allow the connection of the appliance to the New Comando Amico Remoto (CAR ^{v2}) and allow to manage and control the boiler at a distance with great ease.

The boiler has a **standard anti-freeze safety device** that protects it to a minimum temperature of **-5°C** (*optional to -15°C*).

The hydraulic circuit has a copper water-gas heat exchanger and uses a new multi-purpose hydraulic unit made from composite material (ICHS) which houses the hydraulic circuit control devices, as well as the pump (*absolute system pressure switch, adjustable system by-pass, 3-bar calibrated system safety valve, etc.*).

The intake of combustion air inside the sealed chamber and flue extraction are ensured by a fan which is guaranteed to operate correctly by means of a differential flue pressure switch. The parameters to operate the boiler can be set via the buttons, where you can view the operating status, mode and anomalies that have occurred using a digital interface with an easy-to-read backlit display screen, located in the centre of the dashboard. The appliance has an IPX5D electric insulation rating; this means that the boiler is protected against jets of water and high humidity levels.

Main MINI EOLO 24 measurements and connections

Height (mm)	Width (mm)	Depth (mm)
781	440	240

CONNECTIONS				
GAS	DOMESTIC HOT WATER		SYSTEM	
G	AC	AF	R	M
3/4"	1/2"	1/2"	3/4"	3/4"

Key:

- G - Gas supply
- AC - Domestic hot water outlet
- ACV- Solar valve kit DHW inlet (Optional)
- AF - Domestic cold water inlet
- R - System return
- M - System flow
- V - Electrical connection

N.B.: connection group (optional)

Main MINI EOLO X 24 measurements and connections

Height (mm)	Width (mm)	Depth (mm)
781	440	240

CONNECTIONS			
GAS	DOMESTIC	SYSTEM	
G	RR	R	M
3/4"	1/2"	3/4"	3/4"

Key:

- V - Electrical connection
- G - Gas supply
- RU - Storage tank unit return (optional)
- MU - Storage tank unit flow (optional)
- RR - System filling
- R - System return
- M - System flow

N.B.: connection group (optional)

Main MINI EOLO 28 measurements and connections

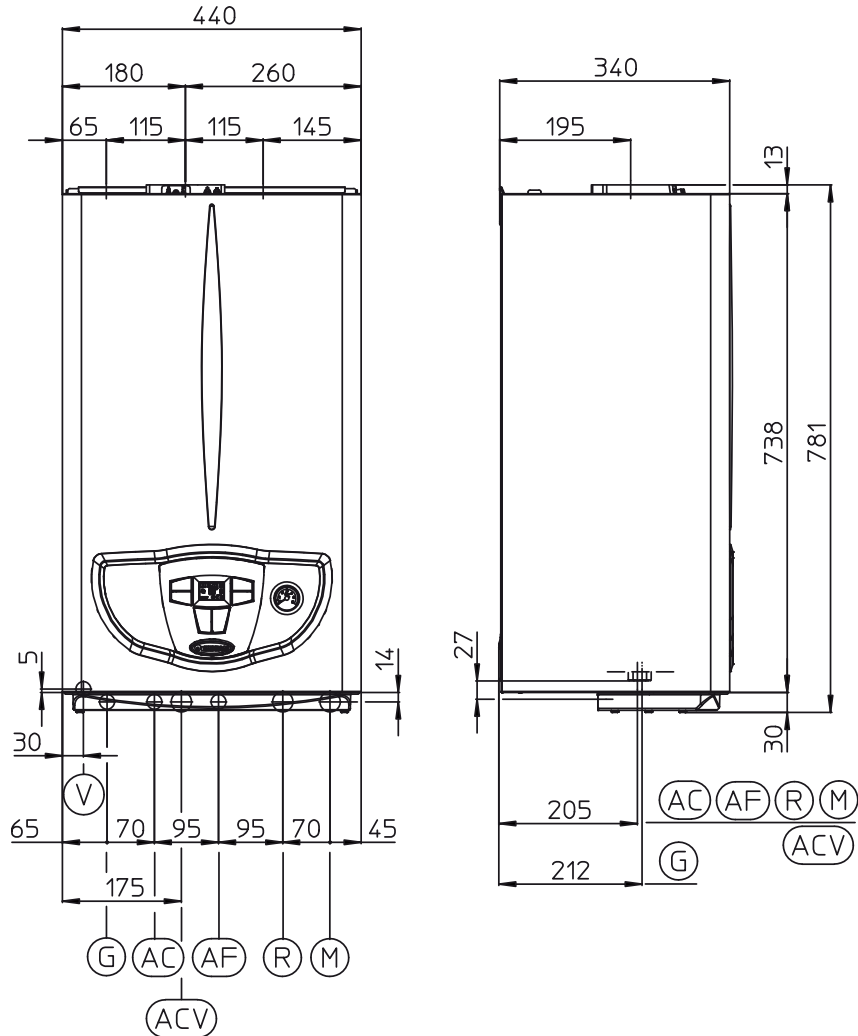

- Key:
- G - Gas supply
 - AC - Domestic hot water outlet
 - ACV- Solar valve kit DHW inlet (Optional)
 - AF - Domestic cold water inlet
 - R - System return
 - M - System flow
 - V - Electrical connection

Height (mm)	Width (mm)	Depth (mm)	
781	440	340	
CONNECTIONS			
GAS	DOMESTIC HOT WATER		SYSTEM
G	AC	AF	R M
3/4"	1/2"	1/2"	3/4" 3/4"

N.B.: connection group (optional)

Main MINI EOLO 24 parts

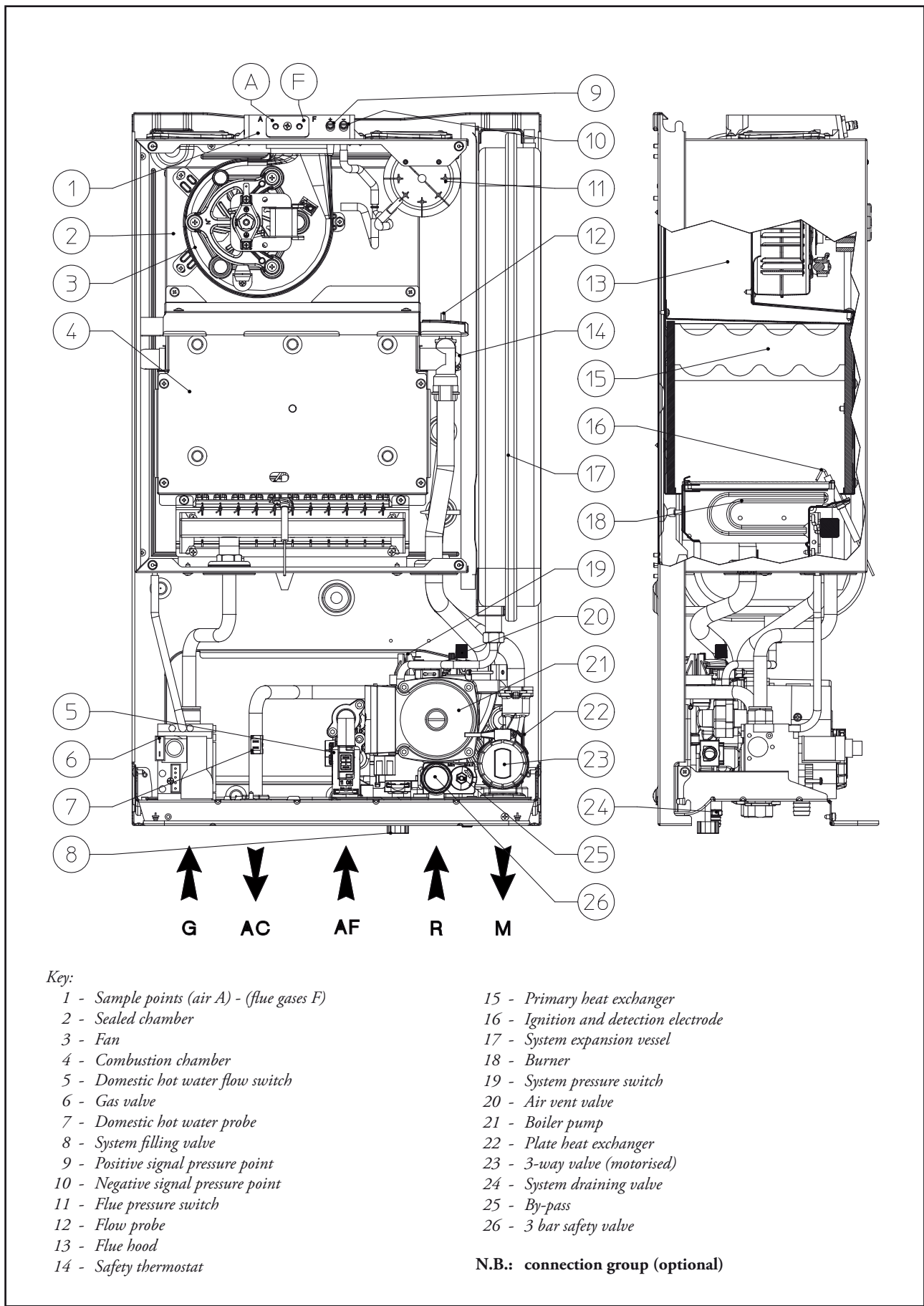

Main MINI EOLO 28 parts

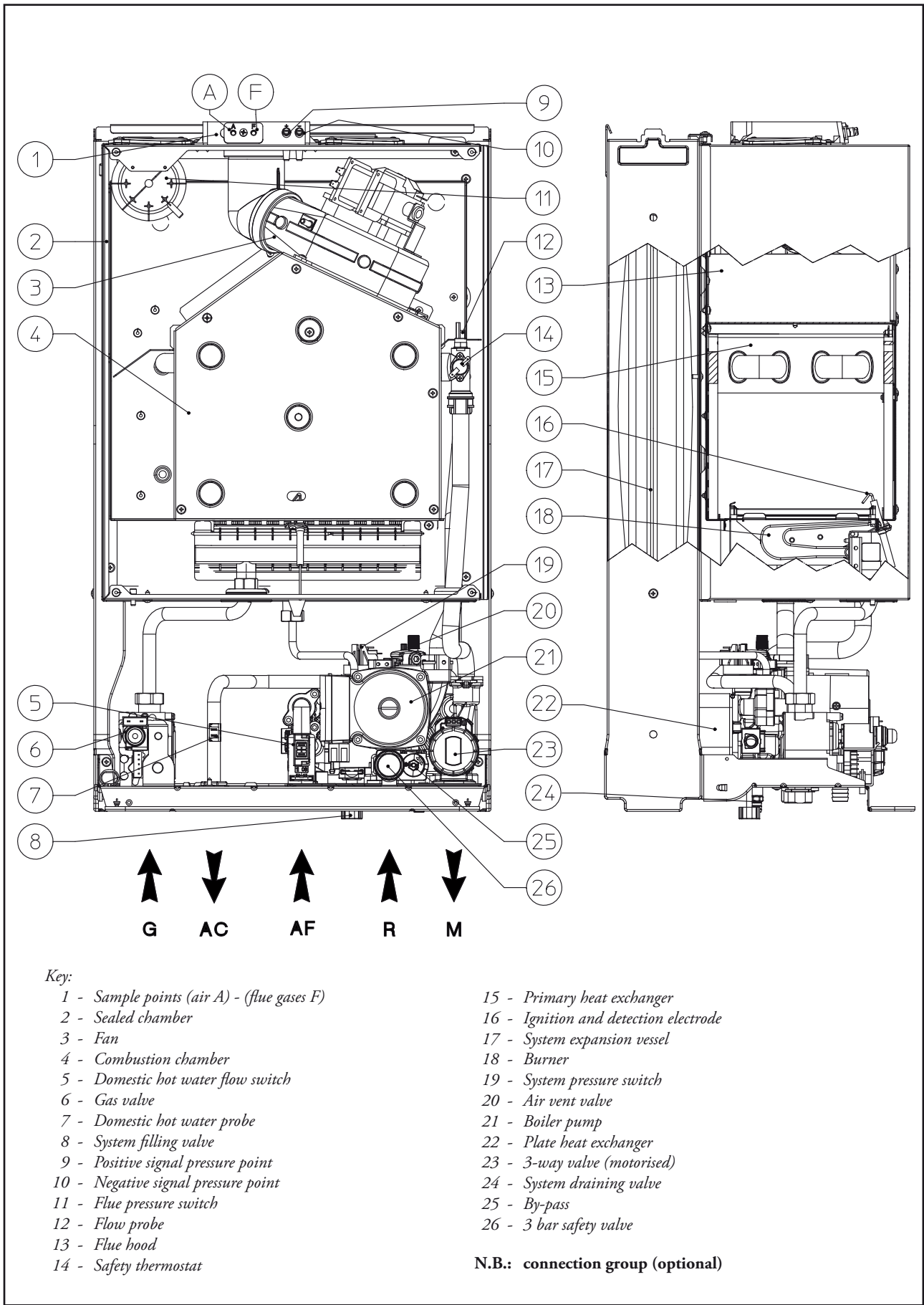

Key:

- | | |
|--|---------------------------------------|
| 1 - Sample points (air A) - (flue gases F) | 15 - Primary heat exchanger |
| 2 - Sealed chamber | 16 - Ignition and detection electrode |
| 3 - Fan | 17 - System expansion vessel |
| 4 - Combustion chamber | 18 - Burner |
| 5 - Domestic hot water flow switch | 19 - System pressure switch |
| 6 - Gas valve | 20 - Air vent valve |
| 7 - Domestic hot water probe | 21 - Boiler pump |
| 8 - System filling valve | 22 - Plate heat exchanger |
| 9 - Positive signal pressure point | 23 - 3-way valve (motorised) |
| 10 - Negative signal pressure point | 24 - System draining valve |
| 11 - Flue pressure switch | 25 - By-pass |
| 12 - Flow probe | 26 - 3 bar safety valve |
| 13 - Flue hood | |
| 14 - Safety thermostat | |

N.B.: connection group (optional)

Main MINI EOLO X 24 parts

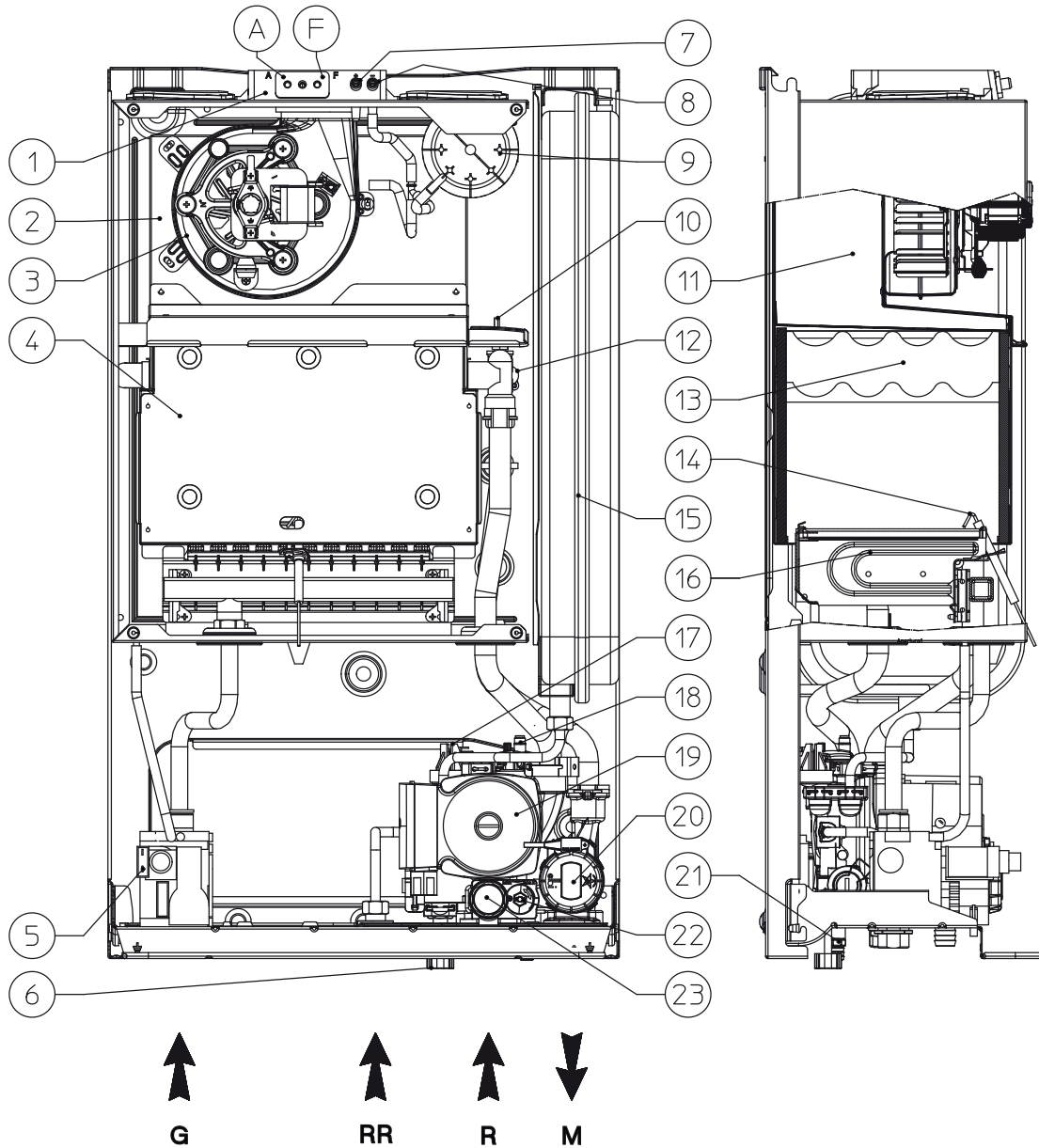

Key:

- | | |
|--|---|
| 1 - Sample points (air A) - (flue gases F) | 15 - System expansion vessel |
| 2 - Sealed chamber | 16 - Burner |
| 3 - Fan | 17 - System pressure switch |
| 4 - Combustion chamber | 18 - Air vent valve |
| 5 - Gas valve | 19 - Boiler pump |
| 6 - System filling valve | 20 - 3-way valve (motorised) (optional) |
| 7 - Positive signal pressure point | 21 - System draining valve |
| 8 - Negative signal pressure point | 22 - By-pass |
| 9 - Flue pressure switch | 23 - 3 bar safety valve |
| 10 - Flow probe | |
| 11 - Flue hood | |
| 12 - Safety thermostat | |
| 13 - Primary heat exchanger | |
| 14 - Ignition and detection electrode | |

N.B.: connection group (optional)

Control panel

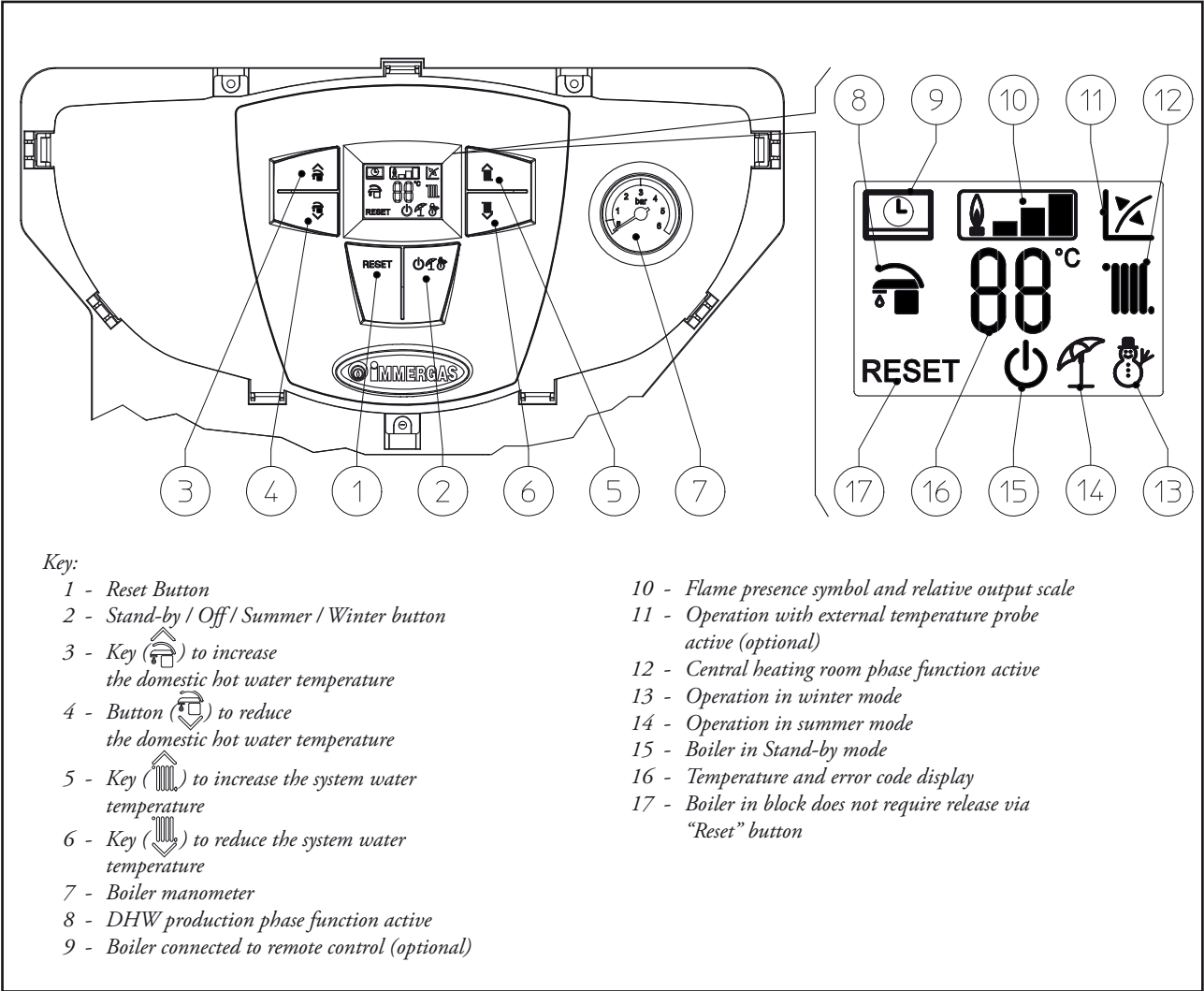

Key:

- 1 - Reset Button
- 2 - Stand-by / Off/ Summer / Winter button
- 3 - Key (↑) to increase the domestic hot water temperature
- 4 - Button (↓) to reduce the domestic hot water temperature
- 5 - Key (↑) to increase the system water temperature
- 6 - Key (↓) to reduce the system water temperature
- 7 - Boiler manometer
- 8 - DHW production phase function active
- 9 - Boiler connected to remote control (optional)
- 10 - Flame presence symbol and relative output scale
- 11 - Operation with external temperature probe active (optional)
- 12 - Central heating room phase function active
- 13 - Operation in winter mode
- 14 - Operation in summer mode
- 15 - Boiler in Stand-by mode
- 16 - Temperature and error code display
- 17 - Boiler in block does not require release via "Reset" button

MINI EOLO 24 hydraulic circuit

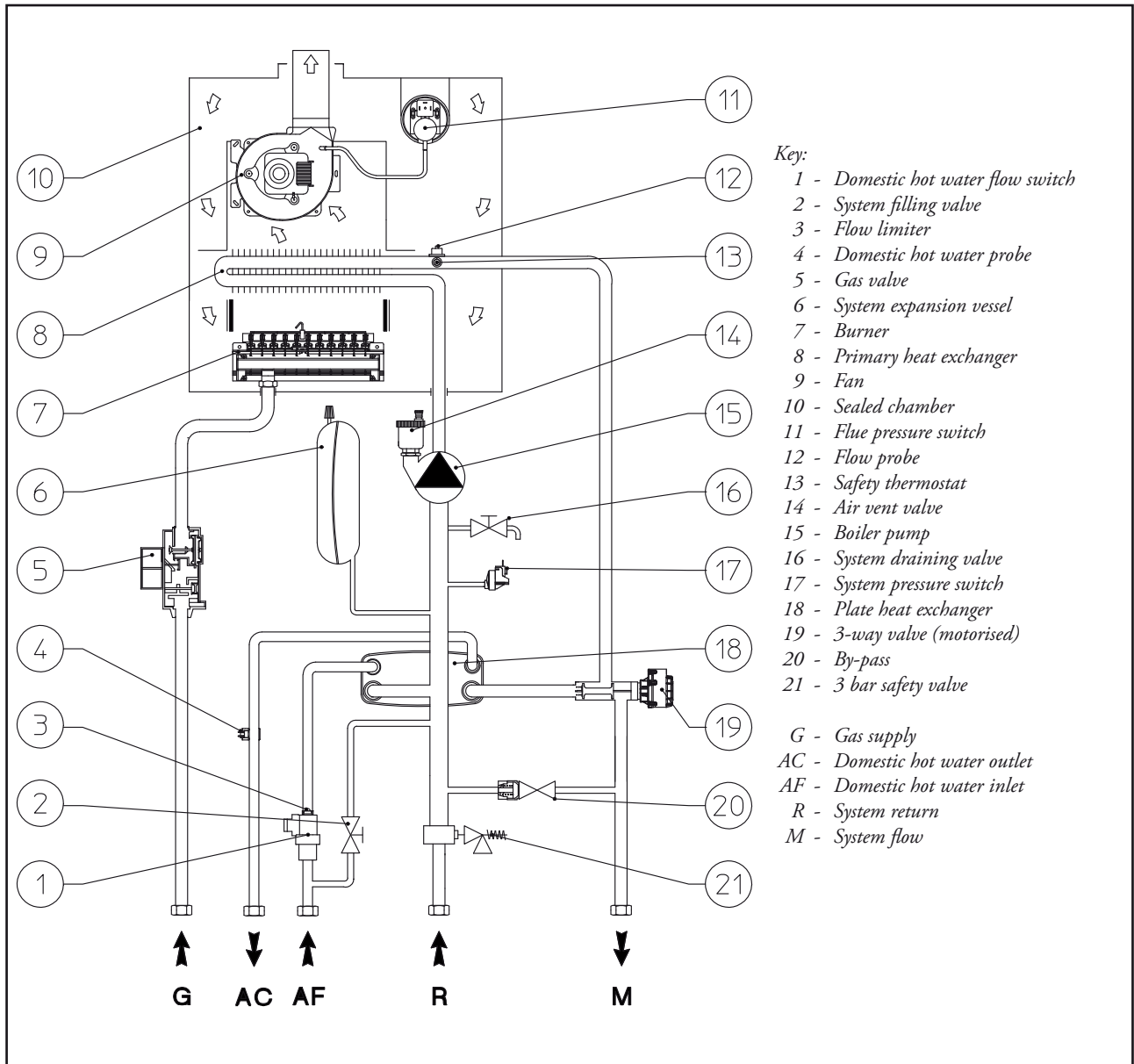

The hot water used for central heating and domestic hot water is produced via a primary and a secondary circuit (DHW) which are affected according to necessity.

MINI EOLO X 24 hydraulic circuit

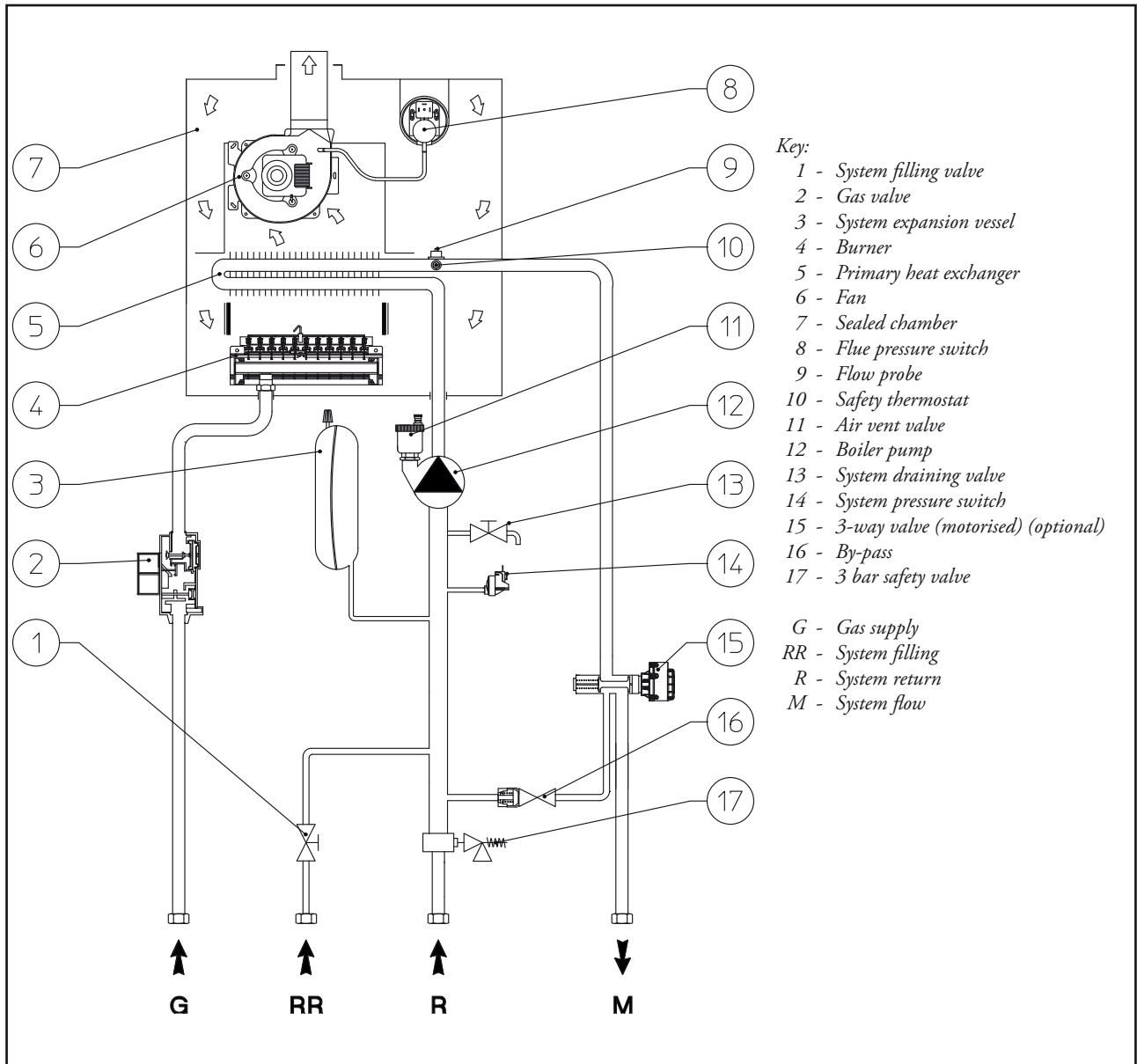

The primary circuit, with relative control and safety devices, is started every time there is a central heating or anti-freeze request.

MINI EOLO 28 hydraulic circuit

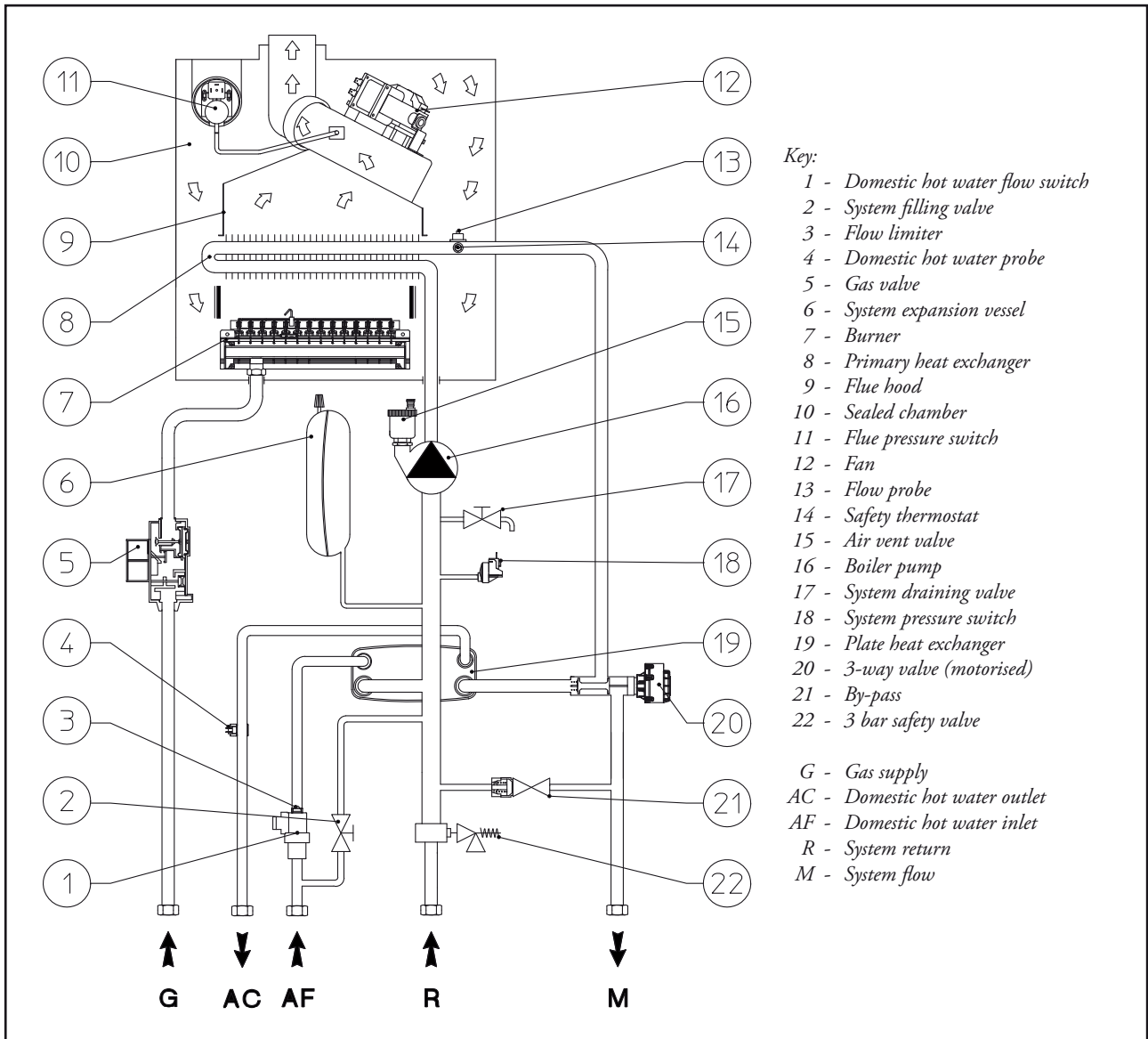

The hot water used for central heating and domestic hot water is produced via a primary and a secondary circuit (DHW) which are affected according to necessity.

Primary circuit (Boiler Circuit)

The primary circuit, with relative control and safety devices, starts up **every time there is a central heating or domestic hot water request.**

How it operates

The heat contained in the flue produced by combustion is absorbed by the copper blades of the water-air heat exchanger (8) which, then transfers the heat to the water that circulates inside by the boiler pump (16).

The water is either sent directly into the system or it can be deviated inside the STAINLESS steel instantaneous plate heat exchanger (19).

This depends on the position of the 3-way motorised valve (20), which allows flow towards the domestic water heat exchanger (19) in its resting position, or deviates it towards the flow (M) and return (R) pipes following a request for central heating.

Head flow rate graphics

The progress of the curve that represents the flow rate-head ratio available to the system depends on the operating speed of the pump which, according to the position, allows you to set more or less head on the system. The graph below illustrates the characteristic curves.

MINI EOLO 24 - X 24

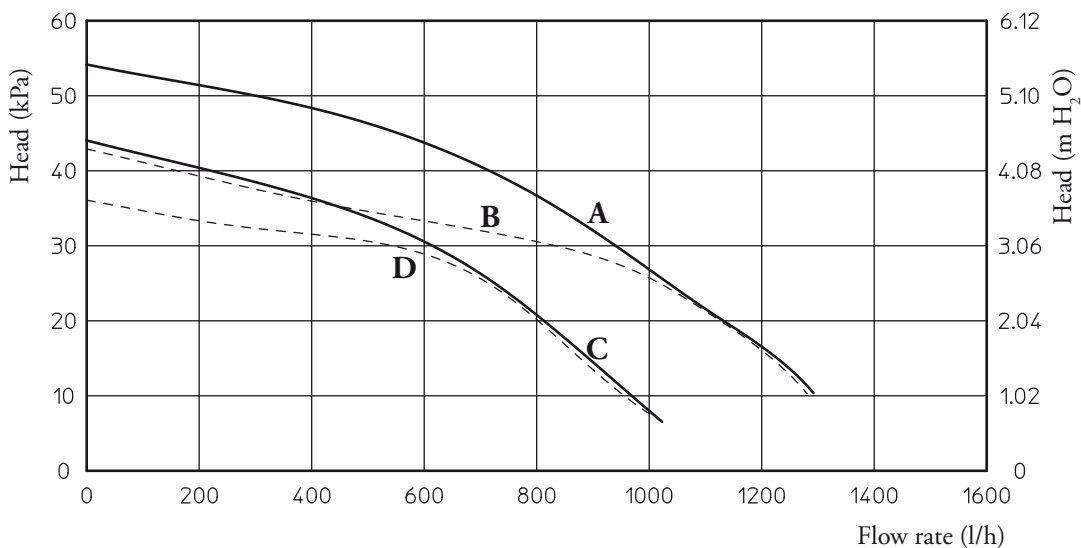

MINI EOLO 28

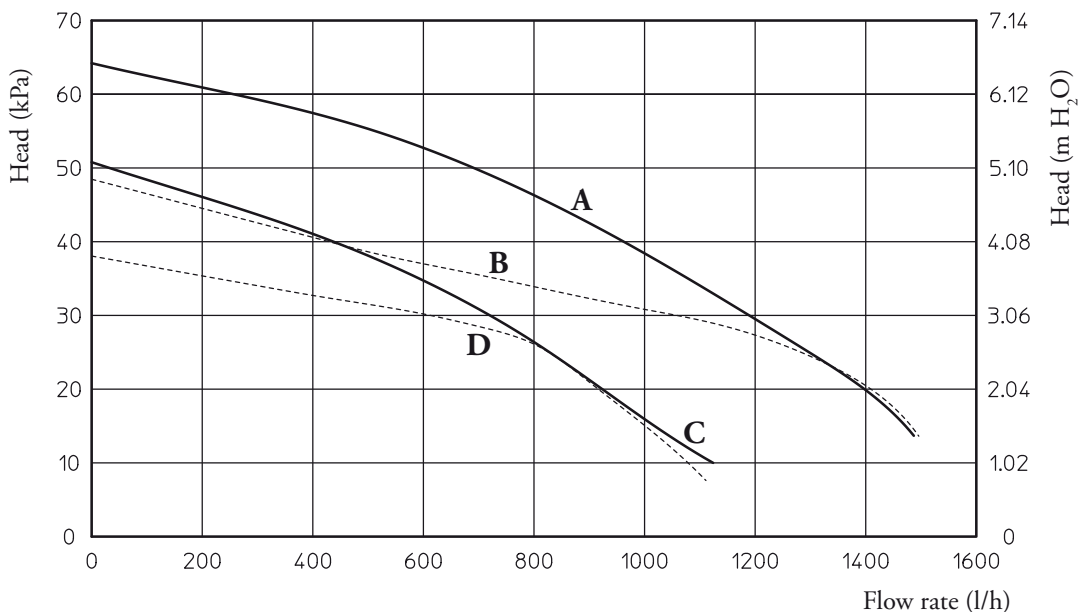

- A = Head available to the system at maximum speed with by-pass excluded.*
- B = Head available to the system at maximum speed with by-pass inserted.*
- C = Head available to the system at second speed with by-pass excluded.*
- D = Head available to the system at second speed with by-pass inserted.*

Boiler pump (1)

Operates on the primary circuit return. It is part of the pump body unit made with composite material.

There is a seat built into the body where the automatic air vent valve (2) is housed with an O-ring sealing.

To remove the air vent valve from the pump body, turn the valve counter-clockwise by a quarter turn.

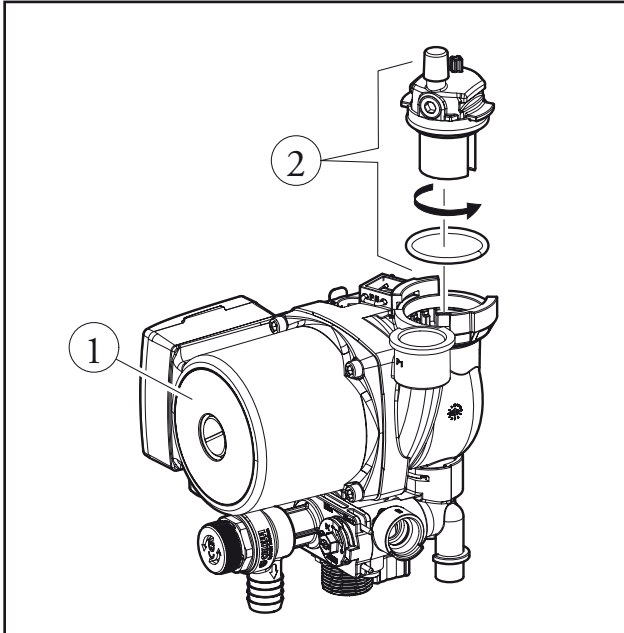

Primary Exchanger (1)

This is a lamellar water-gas heat exchanger with bronze pipes and fins that have the central heating flow NTC probe (6) and the overheating safety thermostat (2) positioned on their outlet (*flow*).

The four pipes that it is made of are connected in series (1). It is connected to the pump flow and to the primary circuit flow using push-fitting pipes (3) with O-ring seal (5) and locked with clips (4).

The heat exchangers for versions 24 and 28 differ in their number of fins (*86 fins in version 24*) (*89 fins in version 28*), and also for the different arrangement for flow and return (*see picture below*).

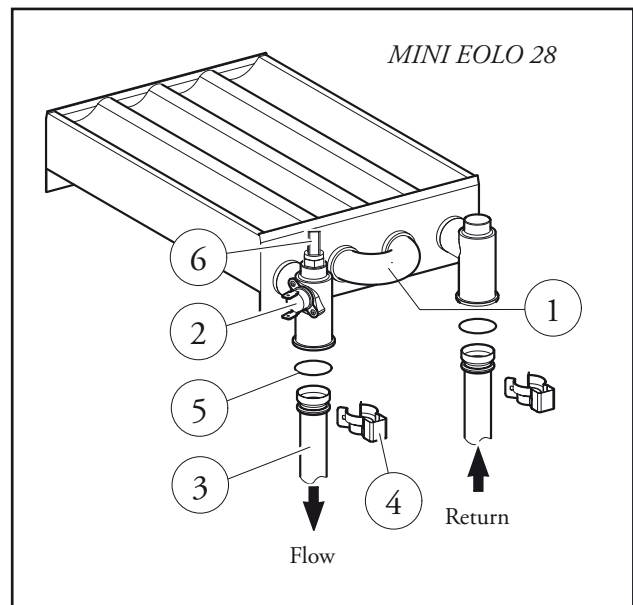
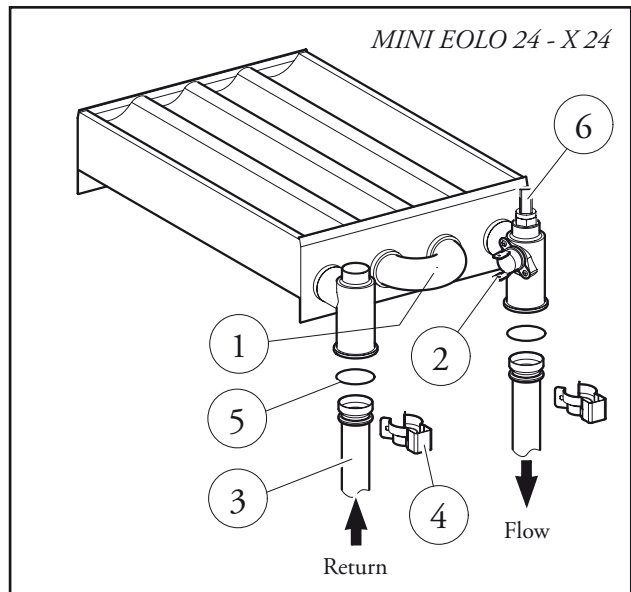

Motorised 3-way valve

This is composed of an electric motor (1) connected to the three-way group (2) with a clip.

Based on the request (*DHW or CH*), the three-way clip allows boiler water to enter the heating system or in the *DHW (plate)* heat exchanger.

This depends on the position of the shutter (4) which closes the passage to the system and at the same time opens the passage to the *DHW heat exchanger (DHW position)*, or vice versa (*CH position*).

The motor (1) is operated by the P.C.B. and moves the shutter (4) in both positions.

The hydraulic part is made of a group built with composite material (2).

Operation during the heating phase

The counter spring (3) for the shutter (4) is not compressed (*heating position*), keeping the passage towards the *DHW (plate)* heat exchanger closed and the passage towards the system flow open.

Both the spring (3) and the shutter (4) are situated inside the body of the 3-way cartridge made from composite material (2).

Operation in domestic hot water phase

The hydraulic group is kept in the *DHW phase position*.

The electric motor (1) pushes the stem (5) that the shutter is attached to (4), closing the passage towards the system, and at the same time opening the passage towards the *DHW (plate)* heat exchanger, compressing the counter spring (3) for the shutter (4) (*DHW position*).

Both the spring (3) and the shutter (4) are situated inside the body of the 3-way cartridge made from composite material (2).

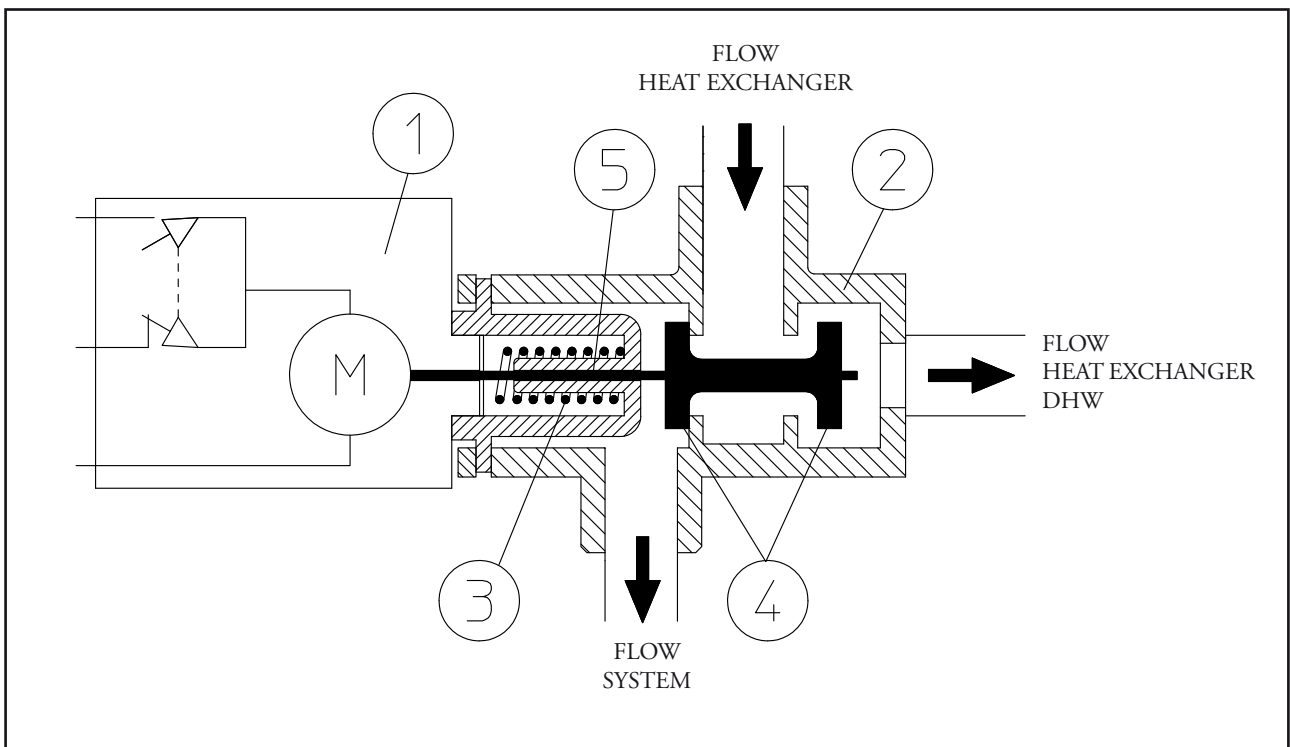
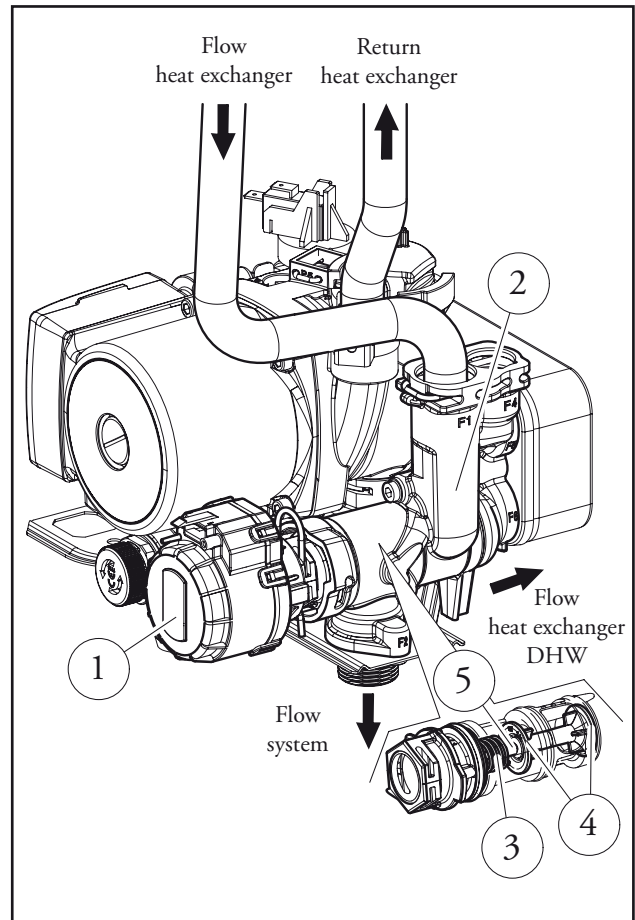

Safety devices and controls

Adjustable system by-pass (5)

This guarantees circulation in the CH circuit even when the high resistance of the system does not allow it. It operates between the flow and return of the CH circuit. It is push-fitted into the top of the pump group (3) and is locked with a clip. It is accessible from the front of the pump group itself and can be adjusted using a screwdriver.

System filling unit (7)

This is a pin valve positioned between the boiler circuit and the domestic cold water inlet that enables the CH system to be placed under pressure. The valve is connected to a manifold (6) which is in turn connected to the cold water input and the pump group with a locking clip.

System pressure switch (1)

It detects the pressure inside the primary circuit. Its seat is built into the pump group (3) and is coupled to a micro switch that prevents the burner from operating when the detected pressure is below 0.3 bar. It prevents the primary heat exchanger from overheating.

Automatic air vent valve (2)

This allows the gaseous substances that may be present in the boiler circuit to be automatically expelled. It is mounted on the pump flow directly on the pump group (3).

3 bar safety valve (4)

This prevents the primary circuit from exceeding the safety pressure (3 bar). It is push-fitted into the front part of the pump group (3) and is attached to the external side using a clip. Its intervention causes water to leak from the boiler return.

Expansion vessel (8)

It compensates the variations in volume caused by heating the water, thus limiting the pressure variations. It has a capacity of 6 litres (*effectively 4.5 litres*) for model 24 and 7.5 litres (*effectively 4.5 litres*) for model 28 and a factory-set pressure of 1.0 bar. Model 24 has a rectangular shape and is positioned on the right side of the boiler at the side of the sealed chamber, while model 28 has a round shape and is positioned at the rear of the appliance behind the sealed chamber. In both models the expansion vessel is connected to the pump group via a bronze pipe.

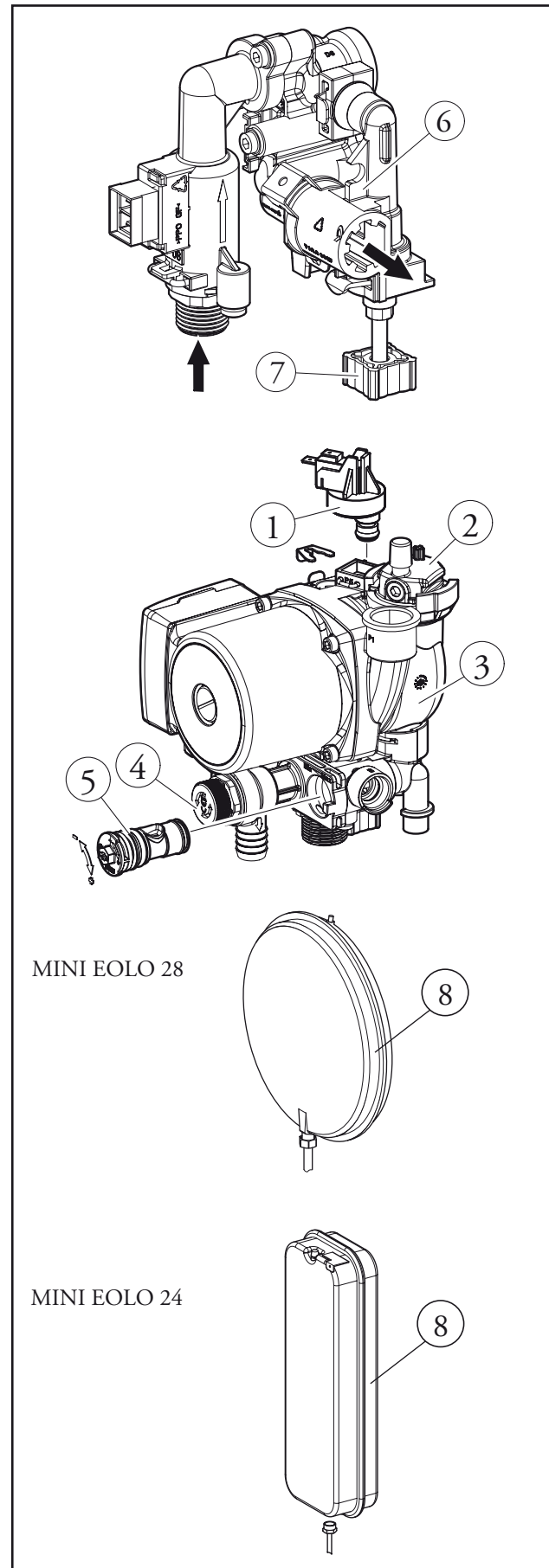

Motorised 3-way valve (optional) for heating only systems

This is composed of an electric motor (1) connected to the three-way group (2) with a clip.

Based on the request (*DHW or CH*), the three-way valve allows boiler water to enter the heating system or the DHW exchanger (*Separate 80, 105, 120, 200 and 300 litre storage tank unit*).

This depends on the position of the shutter (4) which closes the passage to the system and at the same time opens the passage to the DHW heat exchanger (*DHW position*), or vice versa (*CH position*).

The shutter (4) is moved into both positions by powering the motor (1) (*optional*) that causes it to move as needed.

The hydraulic part is made of a group built with composite material (2).

To mount the electric motor (1) push it inside the body of the three-way valve and block it with the designated clip.

Heating only operation

The counter spring (3) of the shutter (4) is not compressed (*heating position*), keeping the passage towards the system flow open.

Both the spring (3) and the shutter (4) are situated inside the body of the 3-way cartridge made from composite material (2).

CH and DHW mode (by using the optional motorised 3-way valve)

The operation is conducted in the same way for combined boilers (*see operation in the previous pages*).

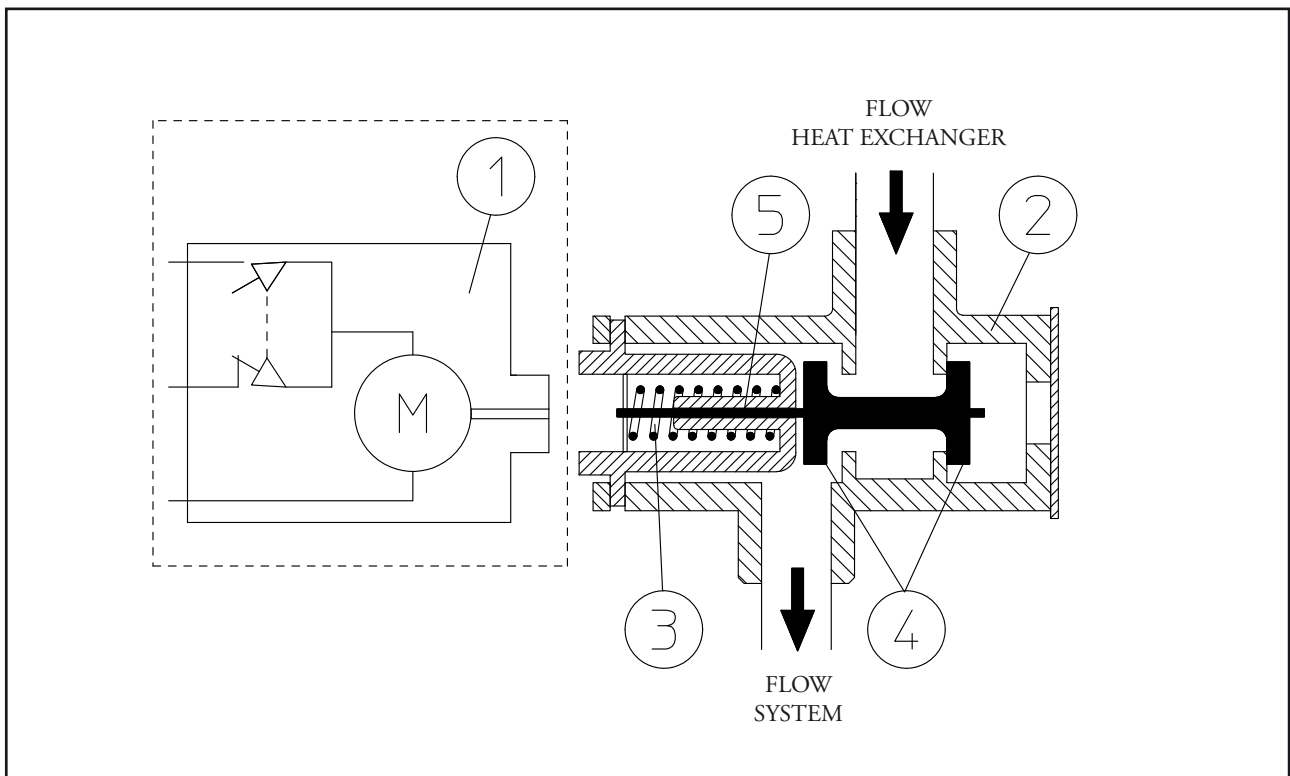
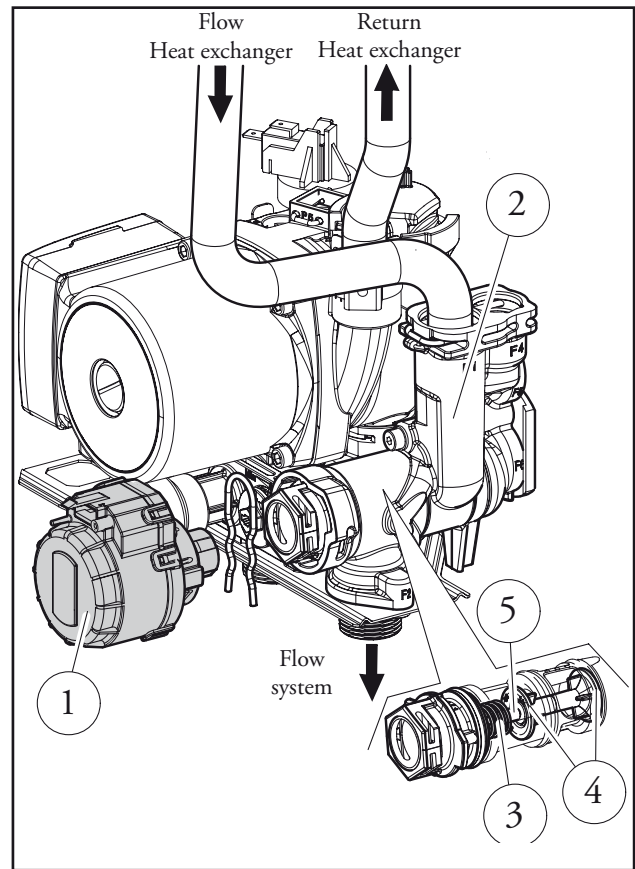

Safety devices and controls for "X" versions (heating only)

Adjustable system by-pass (5)

This guarantees circulation in the CH circuit even when the high resistance of the system does not allow it. It operates between the flow and return of the CH circuit. It is push-fitted into the top of the pump group (3) and is locked with a clip. It is accessible from the front of the pump group itself and can be adjusted using a screwdriver.

System filling unit (7)

This is a pin valve positioned between the boiler circuit and the domestic cold water inlet that enables the CH system to be placed under pressure. The filling unit is connected to the pump unit (3) via an O-ring gasket and blocked with the designated clips.

System pressure switch (1)

It detects the pressure inside the primary circuit. Its seat is built into the pump group (3) and is coupled to a micro switch that prevents the burner from operating when the detected pressure is below 0.3 bar. It prevents the primary heat exchanger from overheating.

Automatic air vent valve (2)

This allows the gaseous substances that may be present in the boiler circuit to be automatically expelled. It is mounted on the pump flow directly on the pump group (3).

3 bar safety valve (4)

This prevents the primary circuit from exceeding the safety pressure (3 bar). It is push-fitted into the front part of the pump group (3) and is attached to the external side using a clip.

Its intervention causes water to leak from the boiler return.

System expansion vessel (8)

It compensates the variations in volume caused by heating the water, thus limiting the pressure variations. It has a capacity of 6 litres (*effectively 4.5 litres*) and a factory-set pressure of 1.0 bar. It has a rectangular shape and is positioned on the right side of the boiler next to sealed chamber and is connected to the pump unit by means of a copper pipe.

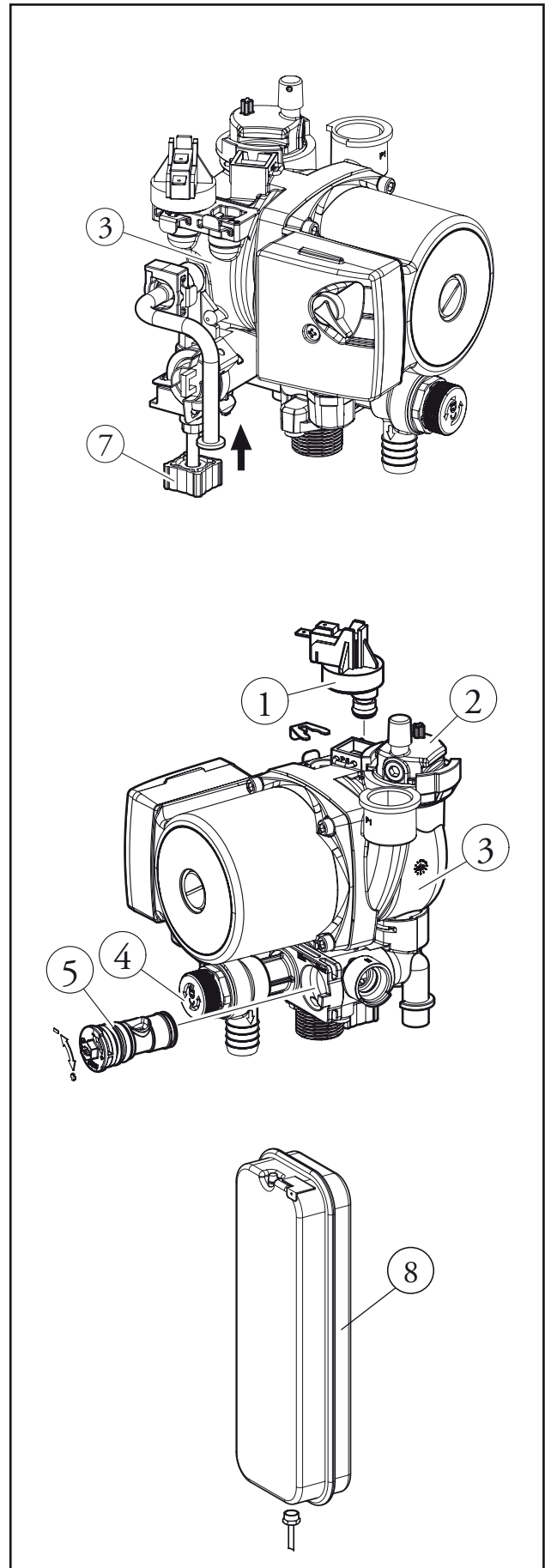

Multipurpose Hydraulic Group ICHS

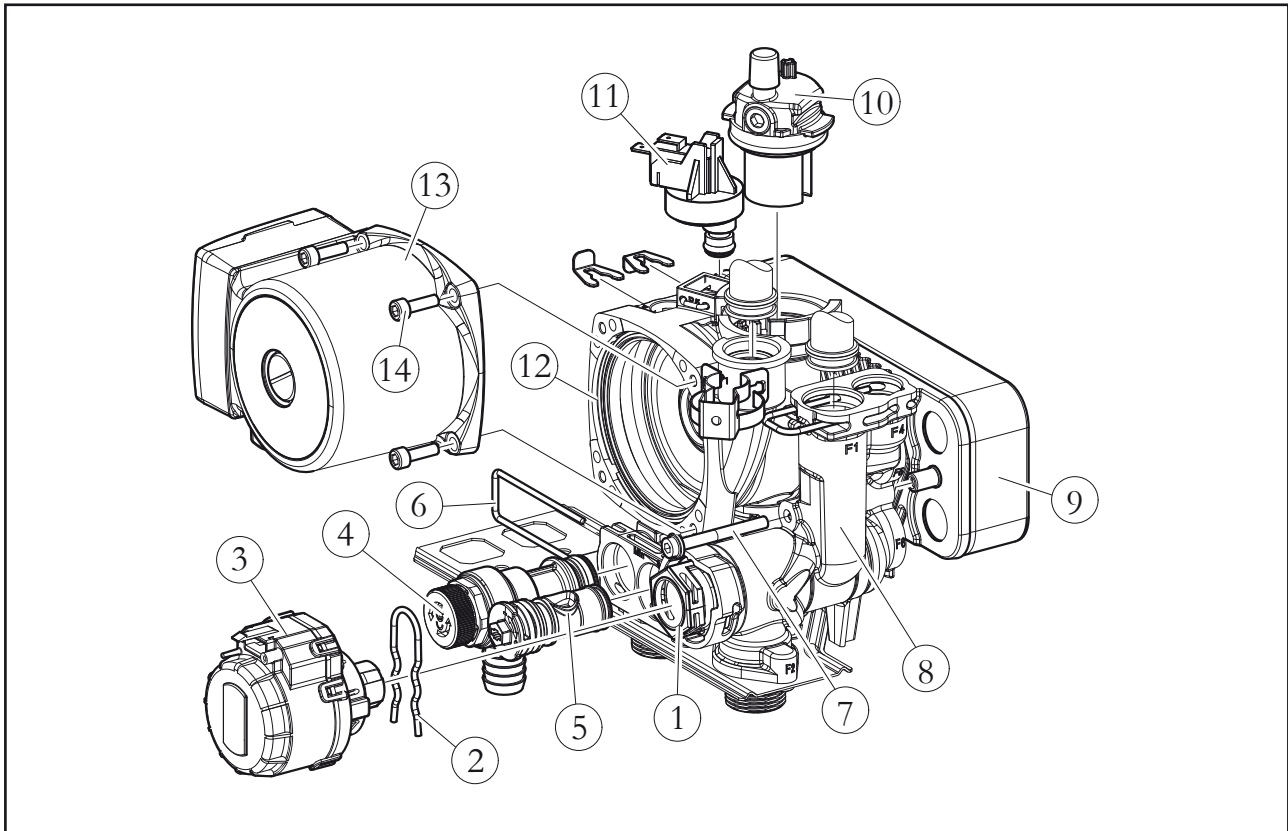

Before replacing the various components found on the ICHS unit, the water present inside the primary circuit must be drained by unscrewing the system draining fitting. Before draining, ensure that the system filling valve is closed.

Three-way valve cartridge replacement

To replace the 3-way cartridge (1) slide the locking clip out (2) and extract the small electric motor (3) and then using a CH 28 key turn the cartridge counter-clockwise so that it detaches from the composite body (8).

N.B.: when you are re-attaching the cartridge you must be very careful not to damage the relative O-ring seal.

Pump motor replacement

To replace the pump body, remove the 4 screws (14) that attach the motor (13) to the composite body (12).

Replacement of the automatic air vent valve

To remove the air vent valve from the pump body, turn the air vent valve counter-clockwise by a quarter turn, being careful not to damage the relative O-ring seal.

N.B.: when re-mounting the air vent valve, pay particular attention to inserting the relative O-ring correctly.

By-pass cartridge replacement

To replace the by-pass cartridge (5) you need to pull out the relative locking clip (6), and then pull the cartridge out from the front.

N.B.: when re-mounting the by-pass cartridge body be careful not to damage the gasket.

3 bar safety valve replacement

To replace the 3 bar safety valve (4) you need to pull out the relative locking clip (6), and then pull the cartridge out from the front.

N.B.: when re-mounting the 3 bar valve, pay particular attention to inserting the relative O-ring correctly.

System pressure switch replacement

To replace the system pressure switch (11), slide the relevant locking clips out.

N.B.: when re-mounting the system pressure switch, pay particular attention to inserting the relative O-ring correctly.

Taking out the plate heat exchanger

To take out the plate heat exchanger you need to remove the two screws (7) that keep the plate heat exchanger fastened (9) to the hydraulic group (8).

N.B.: when you put the plate heat exchanger back in place you need to pay close attention to inserting it correctly and checking the state of the gaskets.

Secondary circuit (Domestic Hot Water Circuit)

How it operates

Use of the DHW leads to cold water passing through the flow switch (1) and the consequent closure of the electric contact that is coupled to it (see electric circuit).

After this, the integrated P.C.B. starts up the phase for DHW priority that causes the burner to turn on, and if a CH request is in underway, it also starts up the deviation of the 3 way valve (2) which subsequently moves to the work position (see how the 3 way hydraulic valve operates).

This causes the flow pipe (M) to close and simultaneously open the passage towards the DHW heat exchanger (3).

In this way circulation inside the CH system is prevented, while it is allowed in the plate heat exchanger, inside which domestic cold water absorbs the heat contained in the primary circuit water (see DHW heat exchanger).

The CH phase is excluded in this phase and priority is given to the production of DHW.

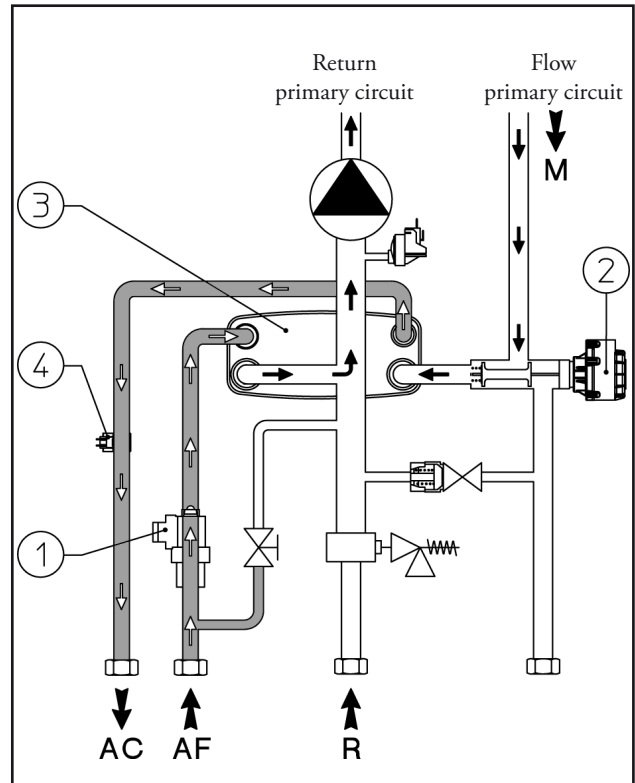

The water/water heat exchange occurs inside the domestic water heat exchanger (3) which is screwed onto the body of the domestic water inlet (1) and the body of the domestic water outlet (2).

The upper left part of the body allows domestic cold water to enter, while the lower part allows the return of the primary circuit.

In the same way the upper part right part of the body allows DHW to flow out and the lower part allows the primary circuit to flow.

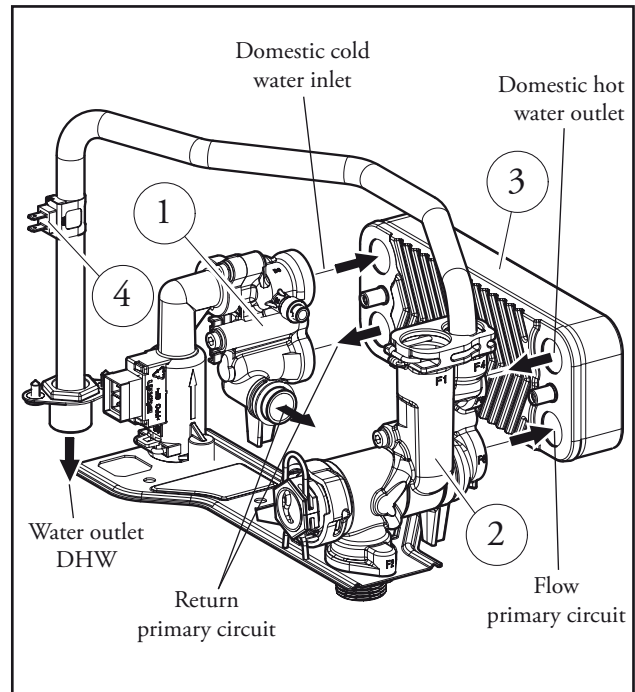

DHW flow switch (2)

With respect to drawing DHW with a flow rate of at least 1.5 l/min and a dynamic pressure of 0.3 bar, the flow switch (1) enables the boiler functioning in DHW mode.

This takes place by means of a magnet which, lifting when it is hit by the flow of domestic cold water, approaches an electric contact (*reed relay*) and causes shifting due to the magnetic effect.

The closure of the contact, which is positioned outside the pipe where the water passes, allows the integrated modulation P.C.B. to start the DHW priority function mode.

It is made up from two parts (*one in brass and one in plastic*) that are coupled and locked with a pin.

A filter (2) is lodged inside of it.

It is attached with two screws to the body of the DHW inlet (4), which, in turn, the system filling group is connected to.

A (2 bar) 7.1 l/min flow rate limiter (3) is inserted at the flow switch outlet for model 24, 9.2 l/min (2 bar) for model 28.

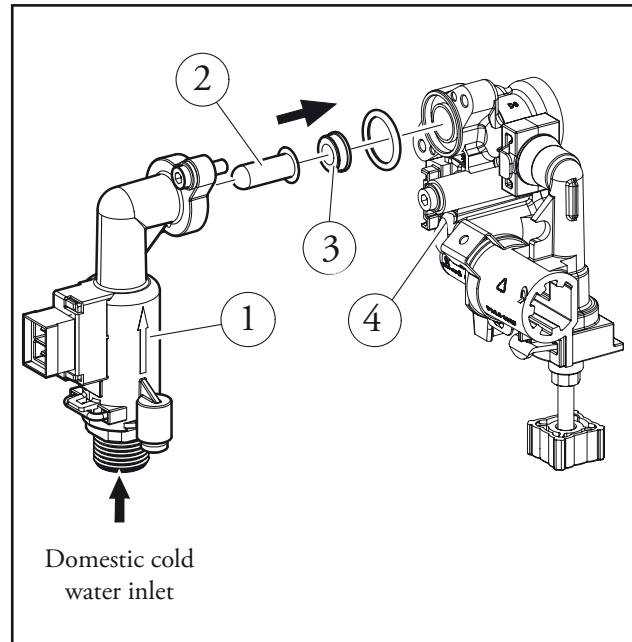

DHW heat exchanger

This is a water-water heat exchanger composed of stainless steel plates laid one on top of the other, 12 (*for model 24*), 14 (*for model 28*) where the water from the boiler circuit and domestic cold water flows over their surfaces, against the flow, and where the heat exchange occurs between the two liquids. The hydraulic coupling is obtained by using four gasket seals (1) that allow it to be connected directly to the domestic water inlet body and domestic water outlet body.

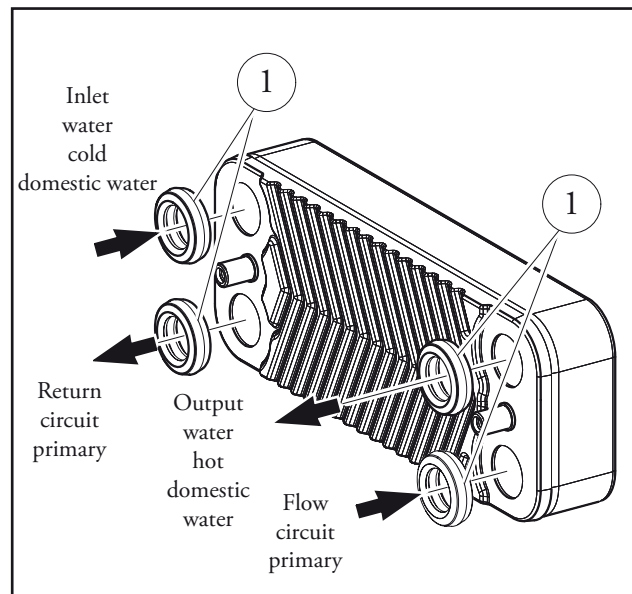

Gas circuit

The circuit is composed of an atmospheric burner and a modulating gas valve, which respectively allow the combustion of the gas and the adjustment of its flow rate.

How it operates

The electric power supply of the main coils (3) causes the opening of both internal shutters of the valve, thus allowing the passage of gas towards the burner. The outlet flow/rate pressure is then adjusted by acting on the gas valve stabiliser by means of the modulation coil (1).

The fuel is injected, by means of the burner nozzles (6), into the horizontal Venturi pipes (*ramps*). Here, an optimal air-gas mixture is obtained that is ignited by the spark of the ignition electrode (4).

Modulating gas valve (SIT 845)

The gas valve is equipped with two main coils (3) and a modulation coil (1) controlled by the integrated P.C.B. The maximum and minimum outlet pressure values are calibrated on the valve (*see gas adjustments*).

Main electric coils (3)

They are two ON-OFF coils that are powered (230 V AC) by the integrated P.C.B. when burner ignition is necessary. They are connected electrically in parallel and powered by the mains voltage through a specific connector (2).

Modulation coil (1)

It is a low voltage coil that is controlled by the integrated P.C.B. It acts on the gas valve stabiliser and allows the variation of the outlet pressure proportionally to the direct current that passes through it.

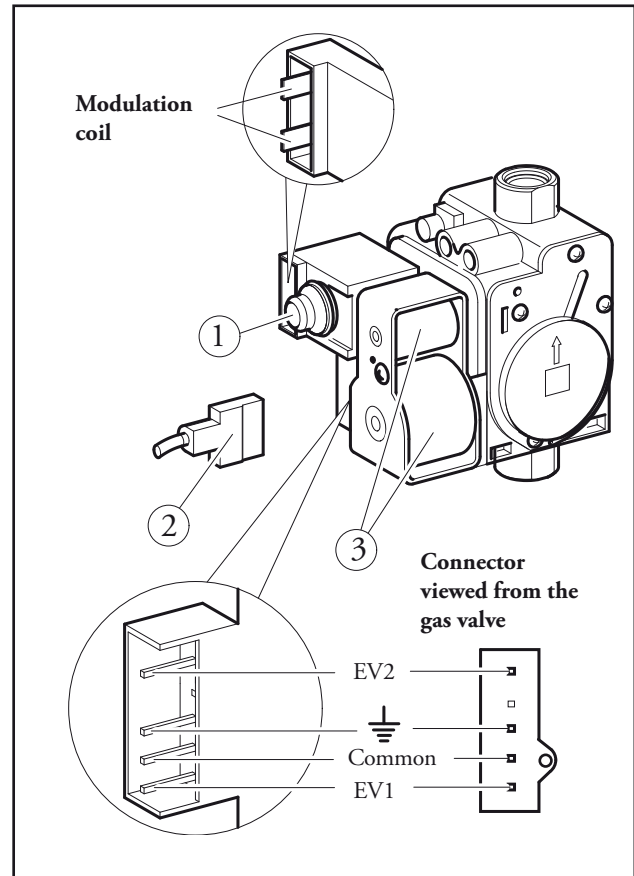

COIL	POWER SUPPLY	RESISTANCE
EV1	230 V AC	6.25 kΩ
EV2	230 V AC	860 Ω
Modulation coil	250mA DC (G20) 320mA DC (L.P.G.)	22 Ω

Standard values for the boiler at maximum capacity

Burner

the burner is composed of horizontal venturi pipes (5) where gas is injected by the same number of nozzles (6) mounted on the specific manifold (7).

The number of nozzles, whose diameter varies according to the type of gas being used (see technical data), is 11 (for version 24) and 13 (for version 28).

Ignition takes place thanks to an integrated P.C.B. that controls the ignition and detection electrode (4).

Ignition and detection electrode (4)

In the ignition mode, it is controlled by the integrated P.C.B. that causes an electric spark between its ends and the surface of the burner on the contact of which the air-gas mix ignites. Once the burner is on, it detects flame presence on the burner allowing the integrated P.C.B. to conclude the ignition cycle and to vary the gas pressure as required.

It is positioned on the front of the burner in correspondence with the central ramp.

Note: for correct ignition and detection of the boiler always respect the quotes stated in the figure here to the right.

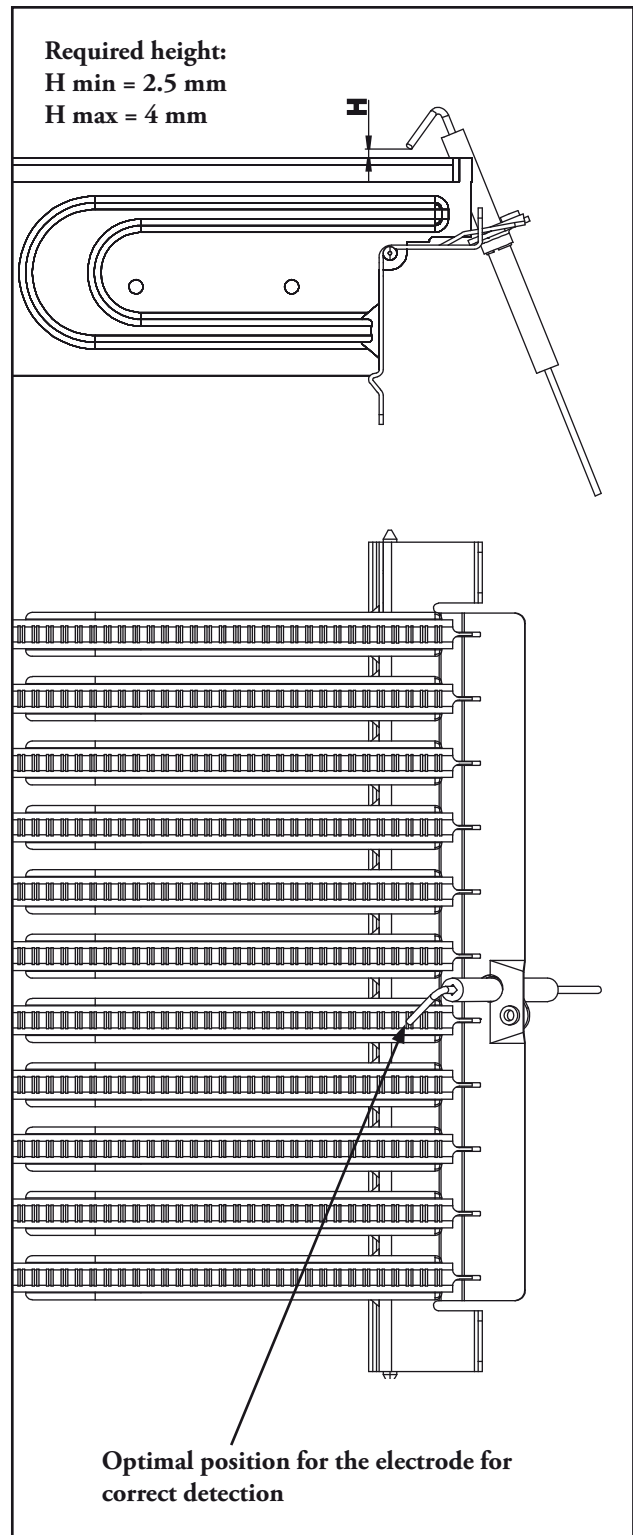
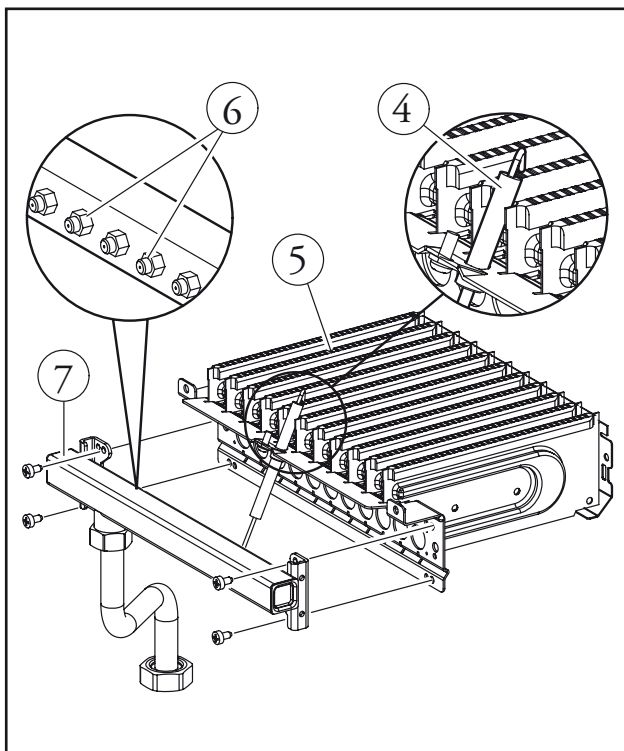

Gas adjustments

The minimum and maximum pressure adjustments are performed by acting on the gas valve and must be carried out respecting the values stated in the tables relative to each generator for the corresponding type of gas (*see technical data*). The measurement is made using a differential manometer whose positive pressure point is connected to the gas valve outlet (4) and to the positive pressure point present in the flange with sample points connected on the upper part of the sealed chamber (*see figure*).

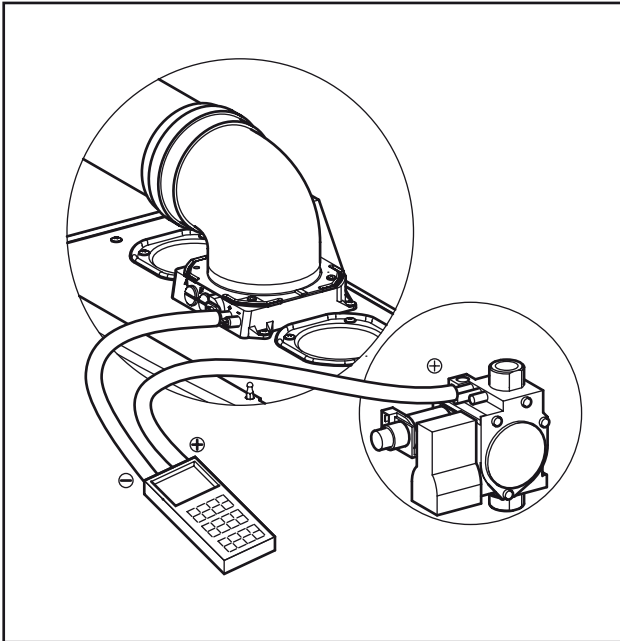

SIT 845 Gas Valve

Maximum pressure adjustment

Draw DHW after having positioned the temperature dial on maximum.

Act in a clockwise direction on the brass nut (3) to increase the pressure to the burner and in a clockwise direction to decrease it.

Minimum pressure adjustment

(to be carried out after adjusting the maximum pressure)

After disconnecting the power supply from the modulation coil, turn the screw clockwise (2) to increase the pressure in the burner and counter-clockwise to reduce it.

Gas transformation

The adaptation to the type of gas different to that for which the boilers are prepared as per standard is performed using the relevant kit (*methane or LPG*).

The transformation consists in replacing the nozzles of the burner and selecting the parameter for the type of gas (G1) on the boiler push button panel; then select **(nG)** for Methane or **(IG)** for L.P.G.

The maximum and minimum DHW pressures are adjusted on the gas valve in the manner described above.

The adjustments of the minimum and maximum outputs in CH mode can be set using parameters (*see integrated P.C.B. functioning*).

The ignition pressure for the burner can be adjusted and set using the "Ignition Output" (G2) parameter with the same value as "Minimum heating output" (*see Operating the integrated P.C.B.*).

SIT 845 Valve

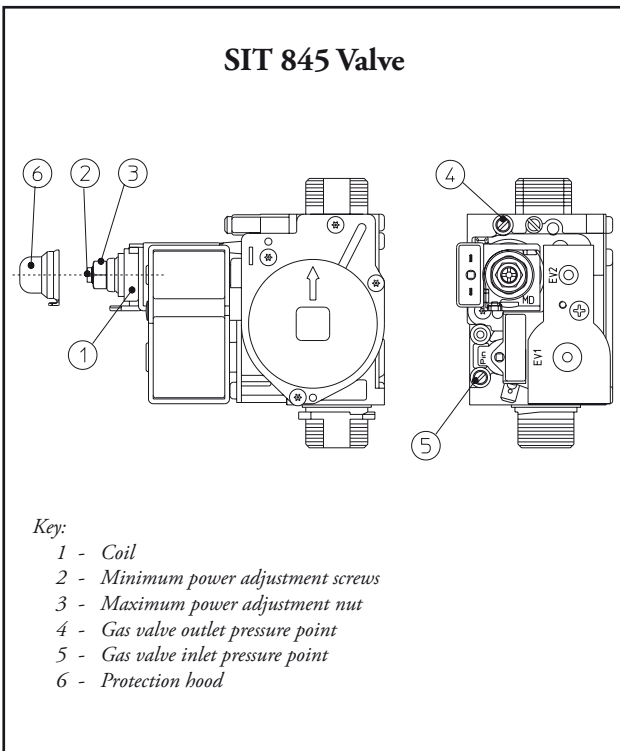

Flue circuit

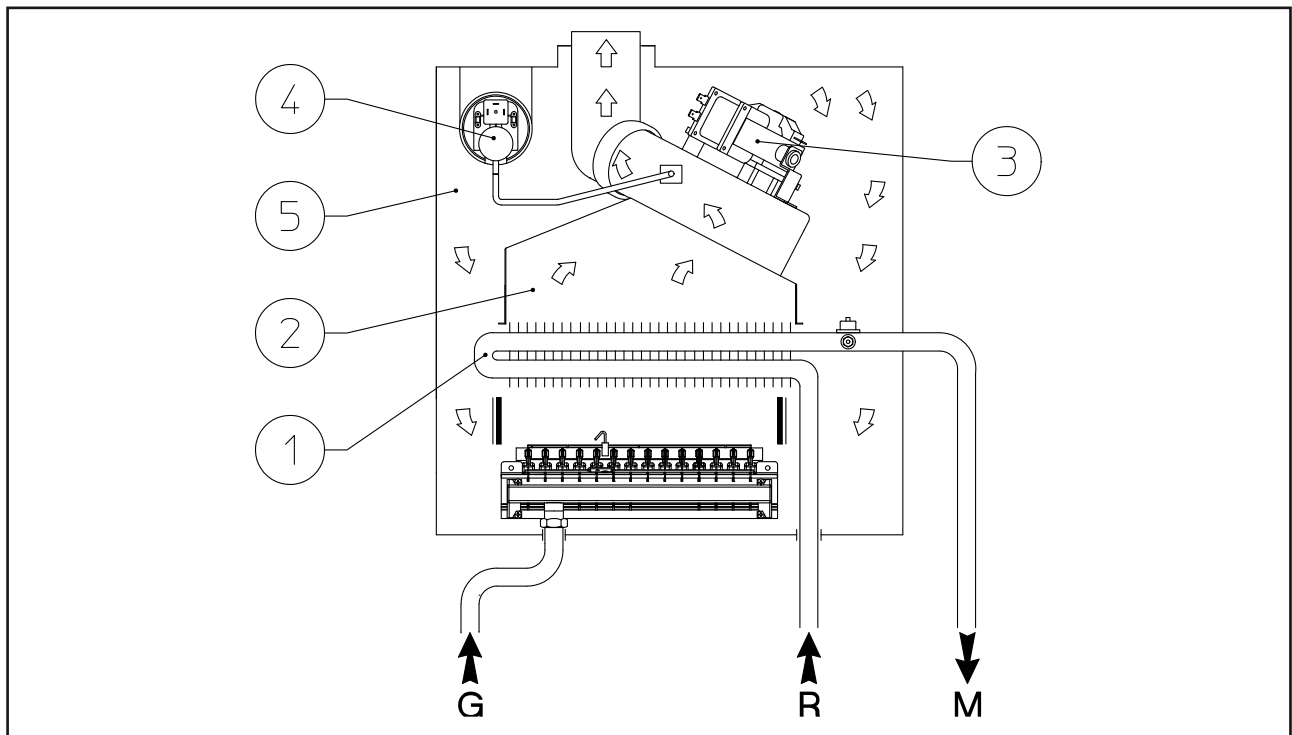

How it operates

The combustion products, after having reached the water-gas heat exchanger (1), are slowed down and distributed by the plate (12), with the consequential increase in combustion yield and then sent to a hood (2) with a flue extractor (3) mounted on top of it (*fan*).

Fan functioning guarantees the forced expulsion of the combustion products and in the meantime creates a depression in the sealed chamber (5). This allows the intake of the combustion agent air from the outside.

The correct evacuation of the combustion products is controlled by a differential flue pressure switch (4) whose intervention enables burner ignition or not.

Flue pressure switch (4)

It is positioned in the upper inside part of the sealed chamber and detects, through the relevant points, the pressure difference **between the inside of the fan (*negative signal*) and the inside of the sealed chamber itself (*positive signal*)**.

The signal measured by the pressure switch is variable according to the length of the intake/exhaust terminals and can be measured by the appropriate pressure points organised in the upper part of the sealed chamber (9-10).

Its intervention causes the closure of a contact (S6) that acts on the integrated P.C.B. enabling burner ignition or not.

Air/flue sample points (7-8)

In the upper external part of the sealed chamber there are two sample points that can be accessed from the front and through which it is possible to draw combustion agent air (7) and combustion products (8).

The two points are closed by a single plastic cap (6).

Flue pressure switch signal pressure points (9-10) (see the figure on the previous page)

There are two pressure points with screw closure positioned on the upper outside part of the sealed chamber. These allow to measure the signal at the ends of the flue pressure switch (4). The negative pressure point (9) is fitted to a "Y"-shaped pipe (11), which is then connected to the negative pressure point of the flue pressure switch (4) **and to the pressure point located on the fan**.

The positive pressure point (10) is connected directly to the inside of the sealed chamber.

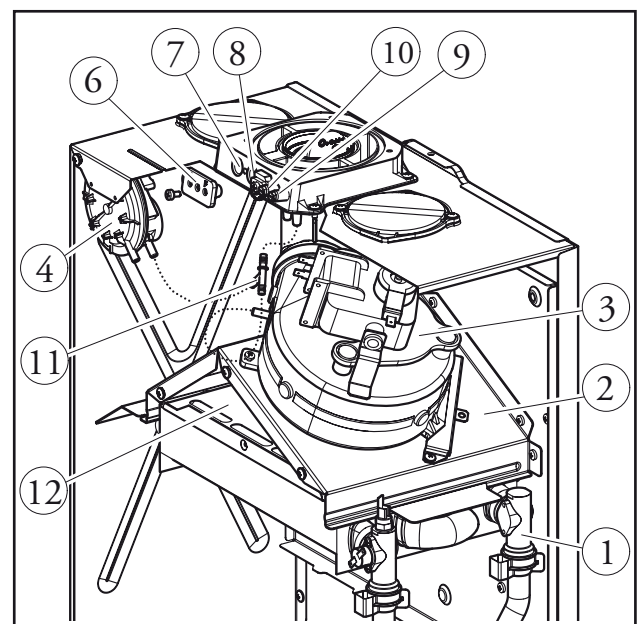

Flue pressure switch intervention pressures	ON Pa (mm H ₂ O)	OFF Pa (mm H ₂ O)
MINI EOLO 24	52 (5.3)	42 (4.3)
MINI EOLO 28	52 (5.3)	42 (4.3)

Fan (3)

The extractor operates downstream from the combustion chamber and is physically "attached" to the upper part of the hood (2) (it is vertically fastened to the upper part of the hood only in the EOLO 24 model), from where it draws out combustion products releasing them into the exhaust pipes to which the boiler is connected. In the meantime it guarantees the flow of air inside the sealed chamber.

It is controlled by the integrated P.C.B. and its functioning coincides essentially with that of the burner.

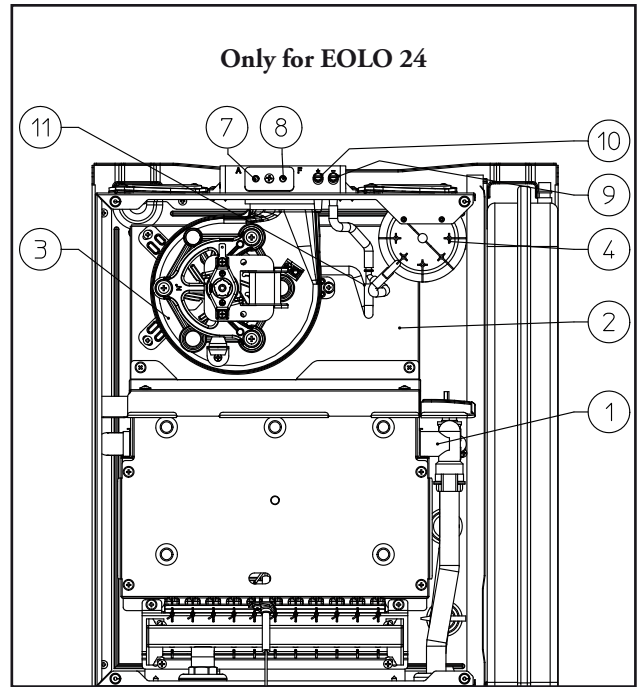

Intake and exhaust systems

(see intake and exhaust terminals instructions)

The MINI EOLO boiler is designed to be connected to the special snap-fit intake/exhaust pipes and can be installed indoors or outdoors (in a partially protected place) in the following configurations:

Outdoor (in a partially protected place):

- with an open chamber and fan-assisted circulation with direct intake using an appropriate top cover kit (optional) mandatory;
- with a sealed chamber and fan-assisted circulation (type C) using the vertical or horizontal concentric kits, keeping the lateral plugs without the obligation to use the top cover kit.

Indoor:

- open chamber and fan-assisted circulation (type B₂₂) using an appropriate top cover kit (optional) mandatory;
- with sealed chamber and fan-assisted circulation (type C) using the vertical or horizontal concentric kits or the Ø 80/80 separator kit.

As for head losses relative to each accessory, the various combinations and use of the diaphragms to be installed according to the length of the pipes, see the instructions relative to the intake and exhaust terminals (boiler instruction manual).

Accessory fitting (bends, extensions, terminals) is the push-fitting type and sealing is assured by relevant silicon lip seals.

Configuration with sealed chamber and fan-assisted circulation with direct intake (type C) for installation outdoors in a partially protected place (see figure at the side)

Using a relevant cover (1) to position on the upper part of the sealed chamber, it is possible to install the boiler outdoors in partially protected places.

Intake

Assembly of the cover (1) envisions the removal of two plugs (3) positioned to close the holes present in the upper part of the sealed chamber.

Combustion air intake takes place directly from the environment, making use of the free space between the lower part of the cover (1) and the upper part of the boiler.

N.B.: in the EOLO 28 version it is essential to cover the right intake hole; vice versa, in the EOLO 24 version it is necessary to cover the left hole with the designated plate (4).

Exhaust

The 80 mm diameter exhaust pipe fitting is obtained using the flange (2) used in the divided systems.

The use of relevant accessories allows horizontal (A) or vertical (B) exhaust.

To prevent condensate problems, the exhaust pipe must be limited to **5 straight metres for normal pipes and 12 straight metres for insulated pipes.**

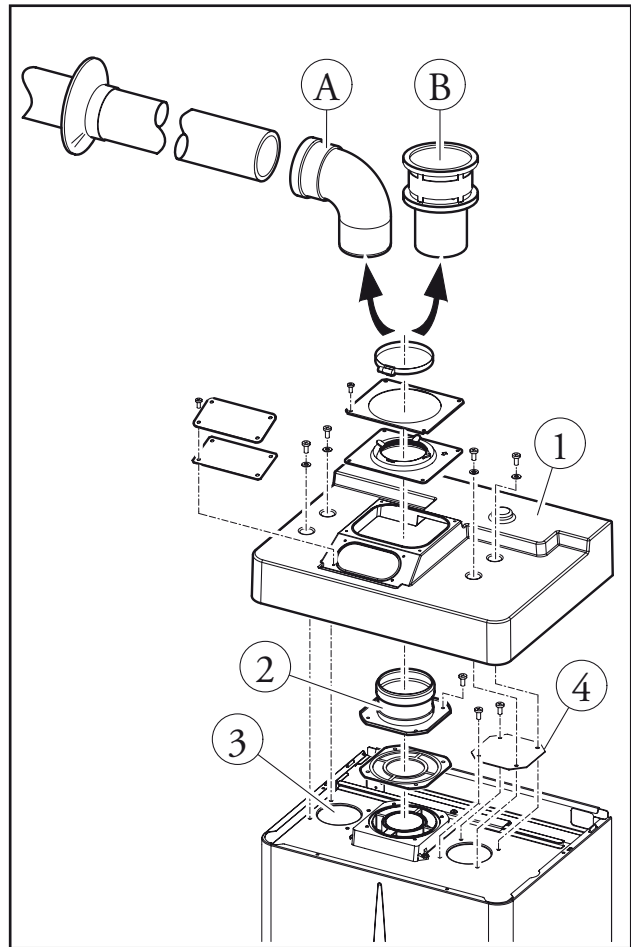

The maximum length allowed is 12 straight metres.

N.B.: To allow the boiler to operate correctly with this kit, it is necessary to install a special diaphragm on the outlet of the sealed chamber and before the exhaust pipe (see boiler instruction manual).

Configuration with open chamber and fan-assisted circulation (type B₂₂) for indoor installation (see figure above).

The previously-described cover kit is used.

By removing the lateral plugs on the sealed chamber, air intake takes place directly in the environment where the boiler is installed.

Flue exhaust takes place through the specific pipes with diameter of 80 in an individual flue or directly to the outside.

Configuration with sealed chamber and fan-assisted circulation (type C)

Exhaust

The connection to the flue exhaust pipes takes place using a flange (1) or a flanged curve to fix to the fitting (4) present on the upper part of the sealed chamber, placing a shaped gasket between them (6).

The flange differs according whether the divided or concentric system is used.

In the first case the passage due to intake of the combustion agent air (5) is closed while in the second case it is made use of. For correct boiler functioning, a diaphragm (7) must be positioned on the exhaust fitting (4), which is placed between the flange used.

There are diaphragms with different diameters and these must be mounted according to the type of pipe and its length (*see boiler instruction manual*).

Intake

Using the divided system, connection to the intake pipes takes place in the same way as the exhaust pipes, being connected to one of the two holes with diameter of 80 mm (2) present in the upper part of the sealed chamber.

The hole not used remains closed by one of the relevant plastic plugs (3) fitted on the boilers.

If co-axial pipes are used, intake of the combustion agent air takes place by making use of the concentric hole outside of the exhaust fitting (5).

Intake and Exhaust Kit

The kits with relative accessories allow the use of four concentric systems and two divided systems.

As for the head losses related to each accessory, the various combinations and use of the diaphragms to be installed according to the length of the pipes, **follow the instructions related to the intake and exhaust terminals** (*see boiler instruction manual*).

Accessory fitting (*bends, extensions, terminals*) is the push-fitting type and sealing is assured by relevant silicon lip seals.

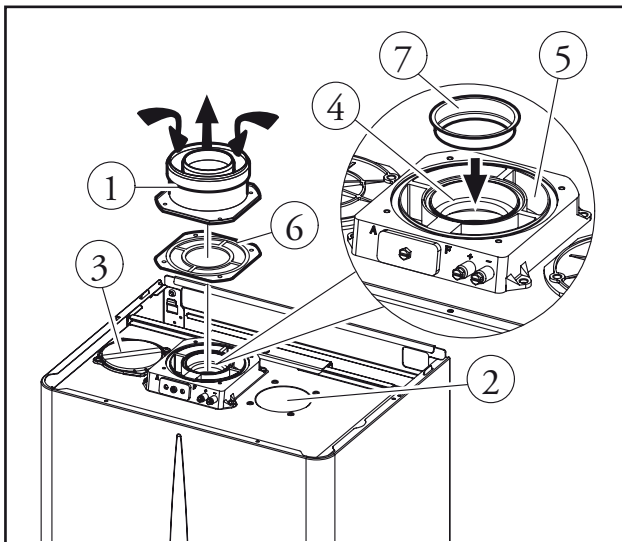

Ø 60/100 push-fitting horizontal concentric kit

The exhaust pipe (Ø 60 mm) is inserted inside the exhaust pipe (Ø 100 mm).

Connection to the boiler takes place using a 90° bend (2), which can be turned in all directions and by using necessary extensions can be connected to the relevant intake and exhaust terminal (3).

The maximum total length allowed beyond the first bend (2) is **3 straight horizontal metres**.

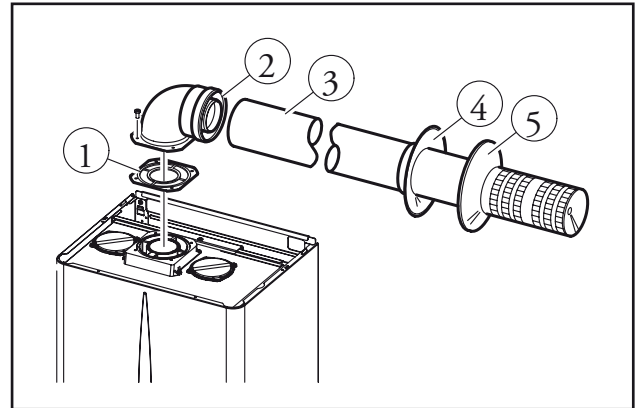

Ø 80/125 push-fitting horizontal concentric kit

The exhaust pipe (Ø 80 mm) is inserted inside the exhaust pipe (Ø 125 mm).

Connection to the boiler takes place with the 90° bend with 60/100 diameter (2). This can be turned in any direction and, by means of a 60/100-80/125 adapter (3) and necessary extensions, is connected to the relevant intake and exhaust terminal (4).

The maximum total length allowed beyond the first bend (2) is **7.3 straight horizontal metres**.

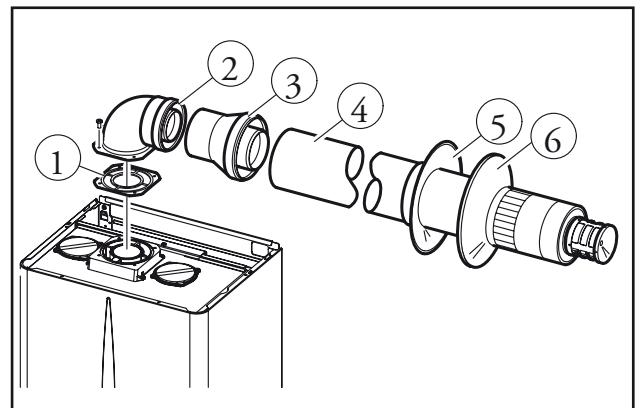

Ø 80/125 push-fitting vertical concentric kit

The exhaust pipe (Ø 80 mm) is inserted inside the exhaust pipe (Ø 125 mm).

Connection to the boiler takes place with a flange (2) which, by means of the 60/100-80/125 adapter (3) and necessary extensions, is connected to the relevant 80/125 intake and exhaust terminal with aluminium tile (6).

The maximum length allowed is **12.2 straight vertical metres**.

Ø 60/100 push-fitting vertical terminal kit

The exhaust pipe (Ø 60 mm) is inserted inside the exhaust pipe (Ø 100 mm).

Connection to the boiler takes place with a flange (2) which, by means of the necessary extensions, is connected to the relevant 60/100 intake and exhaust terminal with aluminium tile (6). The maximum length allowed is **4.7 straight vertical metres**.

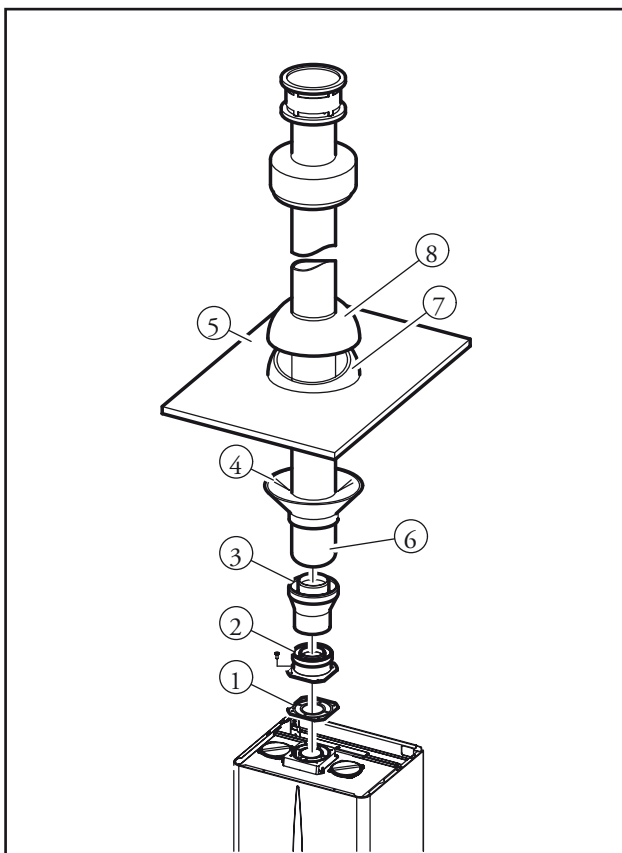

Ø 80/80 push-fitting separator kit

The pipes both have a diameter of 80 mm.

Connections to the boiler take place using the two appropriate flanges that allow exhaust (4) from the central fitting and intake (3) from one of the two lateral holes.

The maximum length allowed (*intake+ exhaust*) is **33 straight horizontal metres and 41 straight vertical metres**.

To prevent condensate problems, the length of the exhaust pipe must be limited to a **max of 5 metres**.

N.B.: Under certain conditions it is necessary to install a diaphragm upstream of the intake pipe (*see boiler instruction book*).

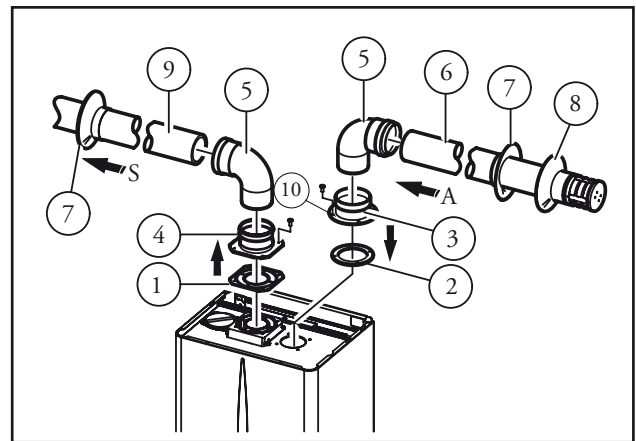

Insulated push-fitting separator kit Ø 80/80

The useful diameter is 80 mm for both pipes.

Connections to the boiler take place using the two appropriate flanges that allow exhaust (4) from the central fitting and intake (3) from one of the two lateral holes.

Insulation is obtained thanks to the specific gaskets (6) that allow to create an air gap with the external concentric pipe of Ø 125 mm.

The maximum length allowed is **33 straight metres** (*intake + exhaust*).

To prevent condensate problems, the exhaust pipe must be limited to a **max. of 12 metres**.

N.B.: Under certain conditions it is necessary to install a diaphragm upstream of the intake pipe (*see boiler instruction book*).

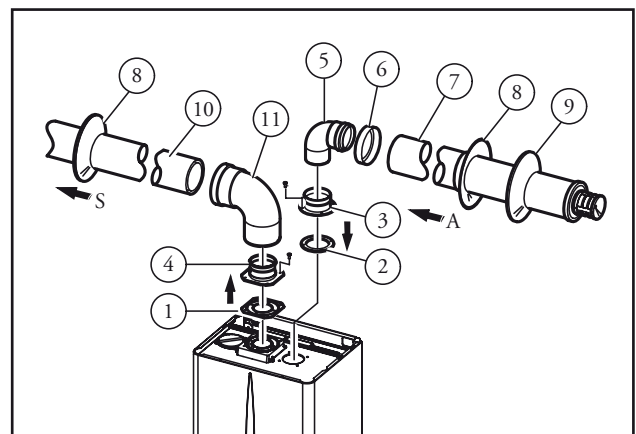

Electric circuit

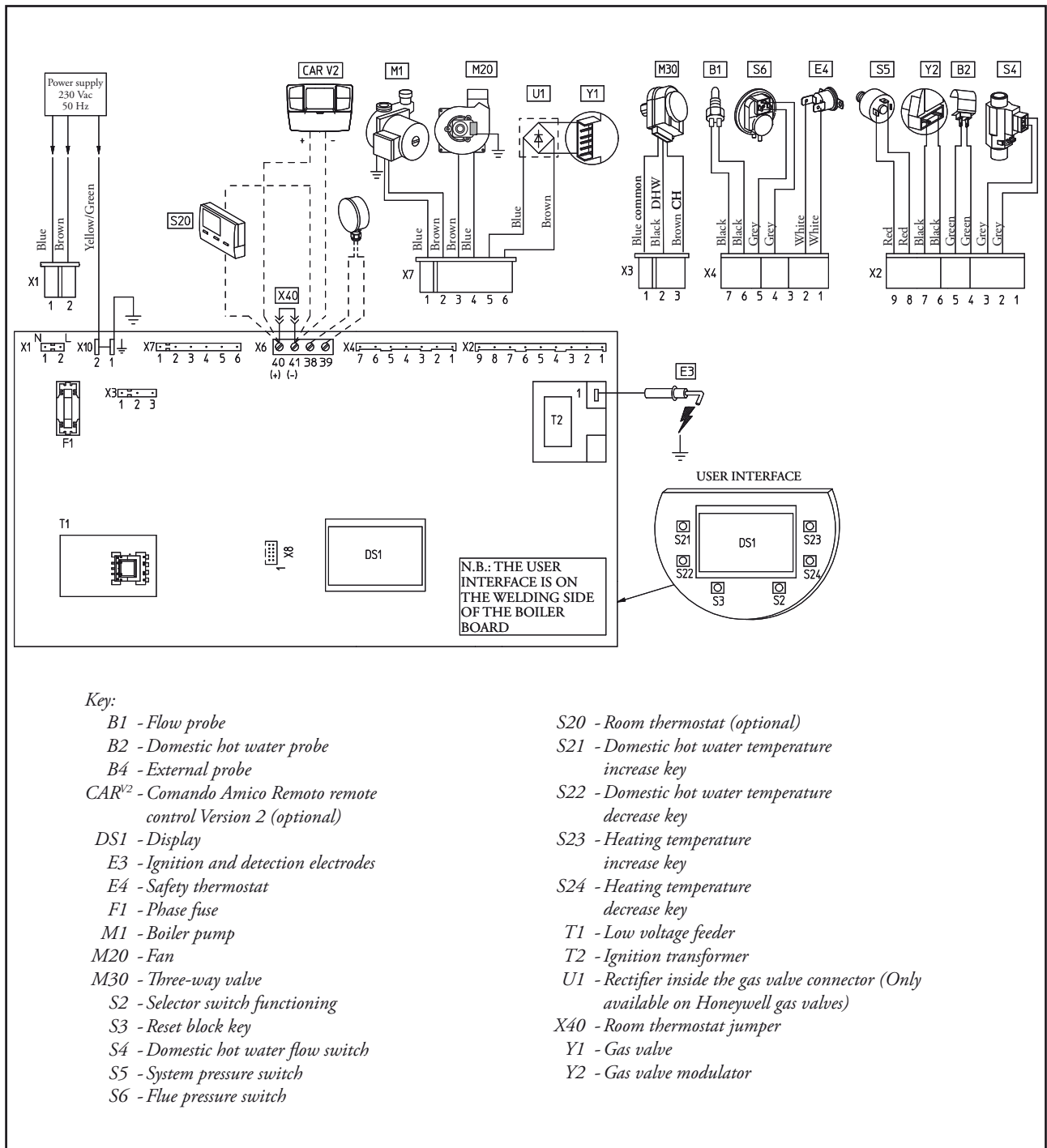

Key:

- B1 - Flow probe
- B2 - Domestic hot water probe
- B4 - External probe
- CAR^{V2} - Comando Amico Remoto remote control Version 2 (optional)
- DS1 - Display
- E3 - Ignition and detection electrodes
- E4 - Safety thermostat
- F1 - Phase fuse
- M1 - Boiler pump
- M20 - Fan
- M30 - Three-way valve
- S2 - Selector switch functioning
- S3 - Reset block key
- S4 - Domestic hot water flow switch
- S5 - System pressure switch
- S6 - Flue pressure switch
- S20 - Room thermostat (optional)
- S21 - Domestic hot water temperature increase key
- S22 - Domestic hot water temperature decrease key
- S23 - Heating temperature increase key
- S24 - Heating temperature decrease key
- T1 - Low voltage feeder
- T2 - Ignition transformer
- U1 - Rectifier inside the gas valve connector (Only available on Honeywell gas valves)
- X40 - Room thermostat jumper
- Y1 - Gas valve
- Y2 - Gas valve modulator

How it operates

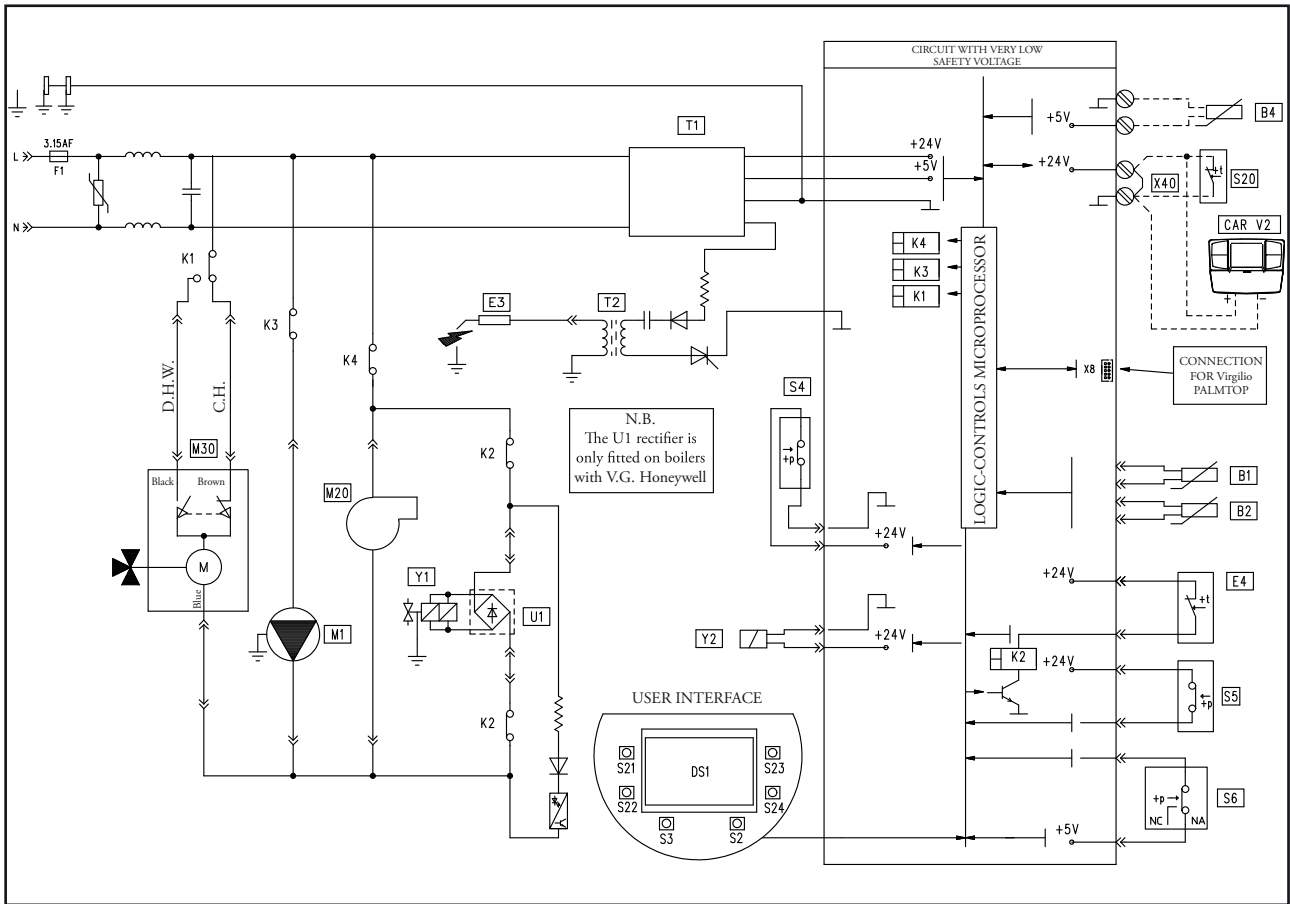

The boiler is equipped with an integrated P.C.B. with microprocessor for control of the appliance's electric devices, which is designed for the linear modulation of burner output. **The board that is fitted on all models, whether they are conventional flue or sealed chamber (MINI NIKE/EOLO) models**, the various boiler operating modes are detected automatically via the appliance's wiring. The P.C.B. carries out a periodical self-check to check it is operating correctly. While operating in CH mode or with the boiler in stand-by, the function goes on every 18 hours from the last check/powering of the boiler. If operating in DHW mode, the self-check starts within 10 minutes after the end of the flow in progress for the duration of about 10 seconds. **N.B.:** during the self-check, the boiler remains off.

Central heating request

By pressing the main button (power icon) boiler activation is enabled. By selecting (winter mode icon) with the button, winter mode (winter mode icon), the CH mode is enabled. On closure of the room thermostat contact (S20), if the system pressure switch contact (S5) is closed (pressure detected in the primary circuit higher than minimum value), the integrated P.C.B. powers the pump (M1) and the motor (M) of the 3-way valve (M30). This functions until the end run switch "3" opens

when the CH position is reached. If the temperature detected by the NTC flow probe (B1) is below the setting made on the boiler control panel with the CH temperature selector and if the flue pressure switch contact (S6) is at rest "NC", the P.C.B. powers the fan (M20). With the subsequent deviation of the flue pressure switch (S6) to "NA" and the consent of the safety thermostat (E4), the integrated P.C.B. allows the ignition cycle to begin by controlling the ignition electrode (E3) and then, both the coils of the gas valve (Y1). The ignition of the burner is detected by the ionisation electrode (E3). In the first seconds after the gas valve has been powered (Y1), the current to the modulation coil (Y2) is limited to the pre-set soft ignition current. Following this the burner comes down to the minimum set value ("Minimum CH output" parameter), to then reach, if necessary, the maximum set value ("Maximum CH output" parameter), in a defined amount of time, "CH ramp with timer" parameter. Successively, flame modulation takes place with reference to the difference between the temperature set on the boiler control panel and that detected by the DHW probe (B1). On exceeding (+5°C) the temperature set, the burner is switched off. The re-ignition time depends of the setting of the "CH ignition timer" parameter.

Every time the burner switches off the fan functions for 30 seconds and the pump continues to operate for 60 seconds.

Operation with Remote Control

In the case of connection to the CAR^{V2} or CAR Universal remote control, the boiler automatically detects the display and the  symbol.

If the conditions detected by the Remote Control require ignition in CH mode (*EST/INV selector of the Remote Control in WINTER position, CH temperature adjustment higher than that detected by the central heating flow probe (B1), request from the time programmer, room temperature adjustment higher than that detected*), the integrated P.C.B. manages the burner ignition cycle, as described previously.

N.B.: By pressing the general button  for 8 seconds and setting the boiler to OFF, on CAR^{V2} the "ERR>CM" connection error symbol will appear and the "CON" symbol will appear on CAR Universal. The Remote Control is powered constantly so as not to lose the memorised programs.

DHW request

Once the domestic water flow switch has been closed (S4), if the system pressure switch contact (S5) is closed (*pressure detected in the primary circuit higher than minimum value*), the integrated P.C.B. powers the pump (M1) and the motor (M) of the 3-way valve (M30). This functions until the end run switch "2" opens once the DHW position has been reached. The burner ignition takes place in the same way as the CH mode.

When the flame has been detected, the modulation coil signal is increased in a way to immediately reach (*if requested*) the maximum output adjusted on the gas valve.

Successively, flame modulation takes place with reference to the difference between the temperature set using the DHW temperature selector switch and the temperature detected by the DHW probe (B2).

Once the set value has been exceeded (+5°C) the burner shuts off, and turns back on again once the temperature goes down again (+4°C) (*factory setting with correlated DHW set-point*).

By acting on the "DHW Thermostat" it is possible to set the boiler so that, once the set value has been exceeded, the burner continues operating at the minimum output and will turn off only when the DHW probe (B2) reads a temperature above 65°C (*fixed DHW set-point*).

If during operation the CH flow probe (B1) reads a temperature above 80°C, it will be modulated by referring to the flow temperature with fixed set-point of 80°C.

DHW request for boilers with storage tank (optional if a "External Storage tank unit coupling Kit is installed).

If the temperature detected by the DHW NTC probe (B2) positioned on the storage tank unit drops below the value defined with the "DHW thermostat" parameter with respect to the set DHW temperature, the boiler starts an ignition cycle in DHW mode.

If the system pressure switch contact (S5) is closed (*pressure*

detected in the primary circuit higher than minimum value), the integrated P.C.B. powers the pump (M1) and the motor (M) of the 3-way valve (M30). This functions until the end run switch "2" opens when the DHW position is reached.

The burner ignition takes place in the same way as in the CH mode.

When the flame has been detected, the modulation coil signal is increased to immediately reach (*if requested*) the maximum output set on the gas valve or that necessary to reach the set temperature.

Successively, flame modulation takes place with reference to the difference between the temperature set using the DHW temperature selector switch and the temperature detected by the DHW probe (B2).

When the temperature measured by the DHW probe (B2) exceeds the value requested, the burner is switched off.

Every time the burner switches off the fan functions for 30 seconds and the pump performs post-circulation for 60 seconds.

If, during functioning, the CH flow probe (B1) measures a temperature higher than 90°C, the burner is switched off. A new ignition cycle can start only if the temperature drops to 75°C.

When the temperature detected by the DHW contained in the storage tank falls below the value defined with the "DHW thermostat" parameter with respect to the set temperature, the P.C.B. starts a new ignition cycle.

Central heating anti-freeze request

When the temperature detected by the CH flow probe (B1) falls below 4°C, the P.C.B. gives consent for ignition and keeps the generator working with the burner at minimum output until a boiler temperature equal to 42°C is reached (*radiators anti-freeze*).

DHW anti-freeze request

If the temperature detected by the DHW probe (B2) falls below 4°C, the P.C.B. gives consent for boiler ignition and keeps the generator working with the burner at minimum output until a temperature of 6°C is reached. Post-circulation is then activated in the central heating mode with duration of 150 seconds.

During functioning, the water in the primary circuit remains below 42 °C as on reaching this temperature the P.C.B. switches the burner off.

If the DHW anti-freeze is activated in concomitance with a central heating request, the DHW anti-freeze is served for 2 minutes and the central heating request for 6.5 minutes (*continuously*).

"Chimney sweep" request

By pressing the "Reset" button for 5 seconds, the P.C.B. will give consent for the generator to ignite in "Chimney Sweep mode", by displaying the symbol  on the screen.

This mode allows the boiler to operate:

- in DHW, if there is a DHW request, at an adjustable output with the CH temperature selector within the useful output range of the boiler.

- in CH at an adjustable output with the CH temperature

selector within the output range set for CH.

During this time the thermostat limit function is enabled through the CH flow (B1) (90 °C) or DHW (B2) (65°C) probe.

The Chimney Sweep mode stops after 15 minutes or it can be stopped by shutting off the power to the circuit, or by setting the operating mode to OFF or Stand-by (⏻).

How it operates with a solar system

The solar function is activated by setting the P9 parameter, "Solar mode, to a value > than 0.

At every request for DHW, the burner and pump will stay off for the amount of time that has been set to allow the DHW coming from the solar storage tank to reach the boiler.

230 V AC high voltage circuit

Inputs

<p>230 V / 50 Hz</p>	<p>The board power supply is connected to the L and N clamps of the X1 connector. - 230 V AC +10% / -15% - 50 Hz +/- 5%</p>	
<p>Ignition and detection electrode (E3)</p>	<p>Detects the ignition of the burner by which the flame is hit and allows the integrated P.C.B. to increase the modulation coil speed (Y2) after having limited it during the ignition phase. It keeps the gas valve open (Y1). It is connected to the detection circuit of the integrated P.C.B.</p>	<p>Flame signal = 6 ÷ 15 microA</p>

Outputs

<p>Ignition and detection electrode (E3)</p>	<p>This is controlled by the integrated P.C.B. with a high voltage signal (<i>greater than 16 kV</i>) which causes an electric spark that ignites the air-gas mixture.</p>	
<p>Boiler pump (M1)</p>	<p>It is powered by the integrated P.C.B. when there is a DHW, CH or anti-freeze request.</p>	
<p>Integrated P.C.B.</p>	<p>The P.C.B. is always powered independently from the position of the  button (<i>see integrated P.C.B. functioning</i>).</p>	
<p>Three-way valve (M30) <i>(X 24 version optional)</i></p>	<p>It allows the diversion of the water flow of the primary circuit to the plate heat exchanger and vice versa. It is powered by the integrated P.C.B.</p>	
<p>Gas valve (Y1) <i>(main coils)</i></p>	<p>It is powered by the integrated P.C.B. when burner ignition is necessary. The SIT 845 gas valve is powered by the mains voltage, the VK 4105 gas valve is powered by the straight mains voltage through a diode bridge (U1) contained inside the gas valve connector. Allows the passage of gas to the burner.</p>	
<p>Fan (M20)</p>	<p>Guarantees the flow of air in the sealed chamber and allows the combustion products to be expelled. It is powered by the integrated P.C.B.</p>	

Safety devices

<p>Phase fuse (F1)</p>	<p>It cuts off the power supply to the circuit when the current absorbed exceeds 3.15A. It is mounted onto the integrated P.C.B.</p>	<p>Fuse 3.15 AF 250 V</p>
-------------------------------	--	-------------------------------

Low voltage circuit

Inputs

<p>Domestic hot water flow switch (S4) <i>(on instant version only)</i></p>	<p>Following the use of DHW, the closure of the contact acts on the integrated P.C.B. causing it to operate in DHW mode. In stand-by it enables functioning in CH mode.</p>	<p>Contact in cut-off</p>
<p>Stand-by/Summer/Winter/Off button (S2)</p>	<p>It sends the board a signal that allows to activate the stand-by status, the functioning in Summer mode (☀) or Winter mode (❄) or to turn off the boiler.</p>	
<p>Reset block key (S3)</p>	<p>It sends the P.C.B. a signal that allows to release the integrated P.C.B. after the intervention of an anomaly or boiler block, signalled with the relative error code.</p>	
<p>Flue pressure switch (S6)</p>	<p>It acts on the integrated P.C.B. and enables burner functioning when the combustion products evacuation takes place correctly. Its eventual closure with the fan off does not enable the start of the ignition cycle.</p>	<p>Contact in exchange</p>
<p>System pressure switch (S5)</p>	<p>When the pressure of the boiler circuit is below 0.3 bar it determines burner switch-off.</p>	<p>Open = No pressure Closed = Pressure OK</p>
<p>External probe (B4) (optional)</p>	<p>Detects the external temperature and allows the integrated P.C.B. to vary the flow temperature depending on the external temperature. It is a resistance that can be varied proportionally to the external temperature.</p>	<p>PTC probe 1 kΩ 25 °C</p>
<p>Flow probe (B1)</p>	<p>It is a resistance variable in an inversely proportionally manner to the temperature of the water. It is positioned at the outlet of the main exchanger, allowing the integrated P.C.B. to detect the temperature of the flow water in the primary circuit. Its breakage (<i>signalled by relative anomaly</i>) blocks burner functioning both in central heating and domestic hot water modes. It is also used as a flow limit thermostat (90 °C).</p>	<p>NTC probe 10 kΩ 25 °C</p>
<p>Domestic hot water probe (B2)</p>	<p>This resistance is variable in a way that is inversely proportional to the temperature of the water; it is positioned on the DHW outlet pipe, allowing the integrated P.C.B. to read its temperature. Its breakage (<i>signalled by relative anomaly</i>) nevertheless allows the boiler to continue working in the central heating and DHW mode. N.B.: for the MINI X 24 it is inserted into a bulb-holder in contact with the external wall of the storage tank.</p>	<p>NTC probe 10 kΩ 25 °C</p>
<p>Room thermostat (S20) (optional)</p>	<p>It enables functioning in CH mode when the room temperature is below that requested. If the CAR^{V2} is installed, the room thermostat must be disconnected <u>without</u> restoring the pre-existing jumper X40.</p>	<p>Open = Central heating OFF Closed = Central heating ON</p>

<p>Safety thermostat (E4)</p>	<p>When the safety temperature is exceeded (100 °C) remove the power supply to the main coils of the gas valve. The P.C.B. displays the "02" error code. It is positioned on the flow pipe at the outlet of the primary heat exchanger.</p>	<p>Klixon thermostat with normally closed contact</p>
--------------------------------------	---	---

Safety devices and controls

Outputs

<p>Gas valve modulator (Y2)</p>	<p>It is powered by the integrated P.C.B. with variable direct current. It allows you to change the gas pressure in the burner based on the required output.</p>
--	--

Management and control devices

<p>Comando Amico Remoto remote control Version 2 (CAR^{V2}) (optional)</p>	<p>Allows long distance control of the generator (<i>SUM/WIN switch, temperature adjustment and indication, alarms display, reset, etc.</i>) and acts as weekly chrono-thermostat. If the CAR^{V2} is installed the pre-existing X40 jumper must be eliminated.</p>	<p>See How CAR^{V2} operates</p>
---	---	---

P.C.B. safety functions

<p>Generic boiler P.C.B. anomaly</p>	<p>In the case of: anomaly on the gas valve pilot circuit; no electric connection to the gas valve (<i>interrupted gas valve coils</i>); error inside the integrated P.C.B.</p>
<p>Fan anomaly</p>	<p>If, once the fan has been powered, no air flow has been detected (flue pressure switch contact is closed), after 20 seconds the anomaly will be displayed. The fan stays on until the flue pressure switch contact has been closed, for the entire duration of the request for heat. If, when the request for heat is on, the air flow is restored (flue pressure switch contact closed), the boiler will automatically start up the ignition cycle.</p>
<p>Three-way valve/anti-block pump</p>	<p>After 24 hours from the last activation, independently from the functioning status of the boiler (<i>Summer or Winter</i>), the pump (M1) is started for a time of 60 seconds and the three-way valve (M30) is started for a period of 10 seconds.</p>
<p>Periodical self-check</p>	<p>The P.C.B. carries out a periodical self-check to control its correct functioning. During functioning in heating mode or with boiler in stand-by, the function activates every 18 hours after the last boiler check/power supply. When operating in domestic hot water mode the self-check starts within 10 minutes after the end of the flow in progress, for a duration of approx. 10 seconds. N.B.: during self-check, the boiler remains off, including signalling.</p>
<p>Parasite flame block</p>	<p>In the case of dispersion of the detection circuit or anomaly in the flame control that generates a correct ionisation current (<i>without the gas valve being open</i>) with the duration of at least 20 seconds, boiler functioning is blocked. To re-start the appliance, press the "Reset" button and then make a central heating or domestic hot water request.</p>
<p>No ignition block</p>	<p>If within 10 seconds from the start of the ignition cycle, the detection electrode (E2) has not detected flame presence on the burner, boiler functioning is blocked. The integrated P.C.B. makes 2 ignition attempts with duration of 10 seconds, intervalled by a time of 30 seconds, after which it blocks. To re-start the appliance, press the "Reset" button and then make a central heating or domestic hot water request. N.B.: it is possible to reset the anomaly up to 5 consecutive times, after which the function is disabled for at least one hour and one attempt is allowed after every hour; or 5 attempts can be gained by shutting off the power supply to the circuit.</p>
<p>Thermostat safety block</p>	<p>If the contact of the water overheating safety thermostat is opened (<i>temperature of the primary circuit exceeding 100 °C</i>), boiler functioning is blocked. To re-start the appliance, press the "Reset" button and then make a central heating or domestic hot water request.</p>
<p>Insufficient circulation</p>	<p>To prevent overheating of the water-gas heat exchanger if the pump is blocked or due to little circulation in the primary circuit, when the CH NTC flow probe (B1) detects an increase in the temperature exceeding 5 °C per second (<i>for more than 2 consecutive seconds</i>), the burner is switched off. Re-start takes place when the flow temperature falls below 43°C.</p>
<p>Boiler pump post-circulation</p>	<p>To prevent overheating of the water-gas heat exchanger, at the end of each CH request (<i>room thermostat opening</i>), DHW, anti-freeze or "chimney sweep" request, the boiler pump (M1) continues working for 30 seconds.</p>

<p>Sealed chamber post-ventilation</p>	<p>The combustion chamber is washed after switch-off of the burner at the end of any request and the fan works for 30 seconds.</p>
<p>Flow NTC breakage (B1)</p>	<p>The breakage of the central heating flow probe (B1) is signalled by the relative anomaly and prevents functioning both in the central heating and domestic hot water modes.</p>
<p>Breakage of the NTC DHW probe (B2)</p>	<p>The breakage of the DHW outlet probe (B2) is signalled by the relative anomaly, <i>(06 for instant boilers and 12 for boilers with a storage tank)</i> but nevertheless allows it to operate in DHW and CH mode.</p>
<p>Flow over-heating ventilation</p>	<p>To prevent overheating of the water-gas heat exchanger, if the boiler temperature detected by the NTC flow probe (B1) exceeds 95 °C, the fan is made to work until the temperature drops below 90 °C.</p>

Operating mode

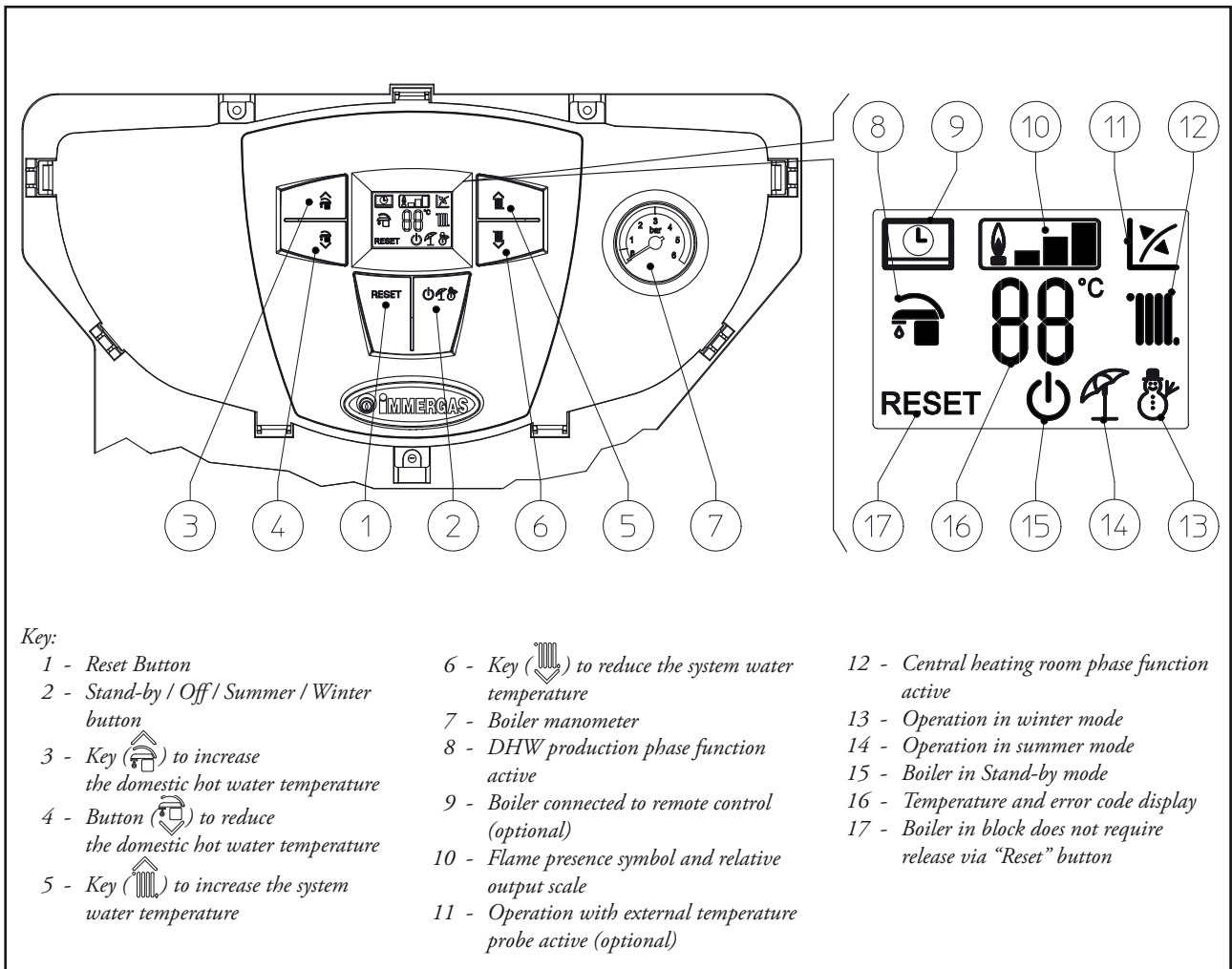

The boiler is supplied with a control panel (where the buttons and temperature selector switches used to control the boiler and set the temperature are positioned) and a display that shows the appliance's functioning mode and status.

By pressing the general button (2), the boiler changes its mode status from Stand-by to On (Summer or Winter).

In Stand-by the P.C.B. safety features are active, such as antifreeze, for example.

By holding general button 2 (⏻) down for 8 seconds the boiler will go into Off status.

In this status the P.C.B. is fully deactivated, including the safety features.

To go back to Stand-by you need to press general button 2 (⏻).

Information Menu

Pressing buttons 3 and 4 for 5 seconds (-) , the "Information menu" is activated, which allows to display some of the boiler's functioning parameters.

Press buttons 3 and 4 (-) to scroll through the various

parameters.

To exit the menu, press buttons 3 and 4 (-) again for 5 seconds or press button 2 () for 5 seconds, or wait for 60 seconds.

Id Parameter	Description
d1	Displays the flame signal (uA)
d2	Displays the primary exchanger output instant heating flow temperature
d3	Displays the instant output temperature from the DHW exchanger
d4	Displays the temperature set for the central heating set (if remote control is present)
d5	Displays the temperature set for the DHW set (if remote control is present)
d6	Displays the external temperature (if external probe present) If the temperature is below zero, the value is displayed flashing.

Programming the P.C.B.

The boiler is prepared for possible programming of several operation parameters. By modifying these parameters as described below, the boiler can be adapted according to specific needs.

To access the programming phase, press the "Reset" and 2 buttons () simultaneously for 8 seconds.

once the programming menu has been entered, the display will alternate the number of the parameter with its current value.

Using keys 3 and 4 (-) select the parameter to be changed, with keys 5 and 6 (-) it is possible to change the value of the selected parameter.

Confirm the changes by pressing the Reset button for about 3 seconds.

Exit the programming phase by waiting for the 15-minute time-out to elapse or by pressing the "Reset" and 2 () buttons together.

Id Parameter	Parameter	Description	Range	Default
P1	Boiler mode (DO NOT MODIFY)	Defines the boiler's functioning mode: 0 - Instant boiler. 1 - Boiler with storage tank.	0 - 1	0
P2	Display lighting	Establishes the display lighting mode: 0 - Off: the display is always lit with low intensity. 1 - Auto: the display lights up when it is used and lights off after 15 seconds of no activity. 2 - On: the display is always lit with high intensity.	0 - 2	2
P3	DHW thermostat	Establishes the switch-off method in DHW mode. 0 - Correlated: the boiler switches off on the basis of the temperature set. 1 - Fixed: the switch-off temperature is fixed on the maximum value independently from the value set on the control panel. In case of "X" version connected to a external storage tank unit coupling kit (optional): 0 OFF 1: The boiler turns off at the Set-point, the boiler turns off at the Set-point -3K. 1 OFF 2: The boiler turns off at the Set-point, the boiler turns off at the Set-point -10K.	0 - 1	1

P4	Minimum CH output	The boiler also has electronic modulation that adapts the boiler potentiality to the effective heating demand of the house. Then the boiler works normally in a variable gas pressure field between the minimum heating output and the maximum heating output depending on the system's heating load. N.B.: the boiler is produced and calibrated in the central heating phase at nominal output. Approximately 10 minutes are needed to reach the nominal heat output changeable using parameter (S1).	0 - 60 %	Functional, as per the final test
P5	Maximum CH output	N.B.: the selection of the “Minimum heating output” and “Maximum heating output” parameters, in the presence of a heating request, allows switch-on of the boiler and power supply of the modulator with current equal to the value of the respective set value.	0 - 99 %	99
P6	Central heating ignitions timer	The boiler has electronic timing, which prevents the burner from igniting too often in central heating mode.	0 - 20 (01 = 30 sec.)	6 (3 min.)
P7	Central heating ramp timer	In the ignition phase, the boiler performs an ignition ramp in order to arrive at the maximum power set.	0 - 28 (01 = 30 sec.)	28 (14 min.)
P8	CH ignition delay from TA and CR request	The boiler is set to switch-on immediately after a request. In the case of particular systems (e.g. area systems with motorised thermostatic valves etc.) it may be necessary to delay ignition.	0 - 20 (01 = 30 sec.)	0
P9	Solar delay timing	The boiler is set to switch-on immediately after a request. for DHW In the case of coupling with a solar storage tank positioned upstream from the boiler, it is possible to compensate the distance between the storage tank and the boiler in order to allow the water to reach the boiler. Set the time necessary to verify that the water is hot enough (see par. Solar panels coupling).	0 - 30 seconds	0

GAS submenu

After entering the programming mode, press button 2 (🔌) for 4 seconds to access this menu.

The parameters can be changed by following the procedure described above.

To exit the menu, press button 2 (🔌) 4 seconds.

Id Parameter	Parameter	Description	Range	Default
G1	Gas type selection	Determines the type of gas being used: nG - Methane lG - LPG Ci – Industrial gas	lG - nG - Ci	The same as the type of gas being used
G2	Ignition power	This establishes the boiler's ignition output.	0 - 50 %	Functional, as per the final test

Fault and anomaly signals

The MINI EOLO boiler will signal any anomaly with the flashing display along with the relative error code as per the table below:

To eliminate the block (where possible), press the RESET button (1).

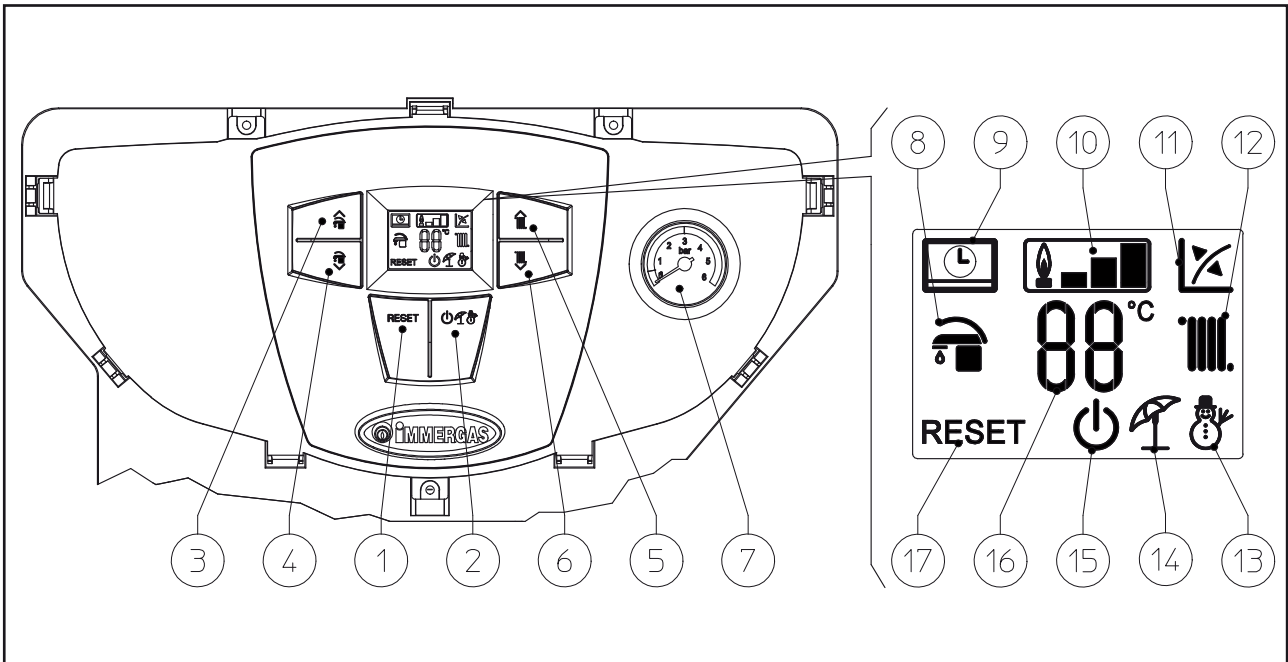

Anomaly signalled	Error code display	Display CAR ^{v2}
No ignition block	01	ERR 01
Safety thermostat block (<i>over-heating</i>), flame control anomaly	02	ERR 02
Fan anomaly	03	ERR 03
Generic boiler P.C.B. anomaly	04	ERR 04
Flow probe anomaly	05	ERR 05
Domestic hot water probe anomaly	06	ERR 06
Maximum reset N° has been reached	08	Not displayed
Insufficient system pressure	10	ERR 10
Flue pressure switch failure	11	ERR 11
Storage tank probe anomaly (<i>with an optional storage tank connection kit for the X version</i>)	12	ERR 12
Configuration error	15	ERR 15
Parasite flame block	20	ERR 20
Push button control panel anomaly	24	ERR 24
Insufficient circulation	27	ERR 27
Loss of remote control communication	31	ERR 31 / CM
Low power supply voltage	37	Not displayed
Loss of flame signal	38	Not displayed
Block due to loss of continuous flame signal	43	Not displayed

MINI EOLO 24 / 28 - Technical Data

		MINI EOLO 24	MINI EOLO 28
Nominal heat input	kW (kcal/h)	25.6 (22051)	29.7 (25536)
DHW minimum heat input	kW (kcal/h)	8.3 (7117)	9.9 (8480)
CH minimum heat input	kW (kcal/h)	10.5 (9057)	12.7 (10902)
Nominal heat output (useful)	kW (kcal/h)	24.0 (20640)	28.0 (24080)
DHW minimum heat output (useful)	kW (kcal/h)	7.2 (6192)	8.5 (7310)
CH minimum heat output (useful)	kW (kcal/h)	9.3 (7998)	11.2 (9632)
Efficiency at nominal heat output	%	93.6	94.3
Efficiency at 30% nominal heat output load	%	90.3	91.5
Heat loss at case with burner On/Off	%	0.80 / 0.60	0.50 / 0.43
Heat loss at flue with burner On/Off	%	5.60 / 0.06	5.10 / 0.04
Central heating circuit max. operating pressure	bar	3	3
Central heating circuit max. operating temperature	°C	90	90
Adjustable central heating temperature	°C	35 - 85	35 - 85
System expansion vessel total volume	l	4.0	7.4
Expansion vessel factory-set pressure	bar	1	1
Water content in generator	l	2.5	2.8
Total head available with 1000 l/h flow rate	kPa (m H ₂ O)	24.52 (2.5)	32.46 (3.3)
Hot water production useful heat output	kW (kcal/h)	24.0 (20640)	28.0 (24080)
Domestic hot water adjustable temperature	°C	30 - 60	30 - 60
Domestic hot water circuit flow limiter at 2 bar	l/min	7.1	9.5
Min. pressure (dynamic) domestic hot water circuit	bar	0.3	0.3
Domestic hot water circuit max. working pressure	bar	10	10
Minimum D.H.W. flow rate	l/min	1.5	1.5
Specific flow rate (ΔT 30°C)	l/min	11.5	13.4
Flow rate capacity in continuous duty (ΔT 30°C)	l/min	11.8	13.6
Weight of full boiler	kg	34.5	40.8
Weight of empty boiler	kg	32.0	38.0
Electrical connection	V/Hz	230/50	230/50
Power input	A	0.66	0.74
Installed electric power	W	130	130
Pump consumption	W	87.0	84.0
Fan consumption	W	35.0	41.0
Equipment electrical system protection	-	IPX5D	IPX5D
NO _x class	-	3	3
Weighted NO _x	mg/kWh	138	107
Weighted CO	mg/kWh	95	92
Type of appliance	C12 / C32 / C42 / C52 / C82 / B22p / B32		
Category	II2H3+		

- Flue temperature values refer to an air inlet temperature of 15°C.
- The data relevant to domestic hot water performance refers to a dynamic inlet pressure of 2 bar and an inlet temperature of 15°C; the values are measured directly at the boiler outlet considering that to obtain the data declared mixing with cold water is necessary.

- The max. sound level emitted during boiler operation is < 55dBA. The sound level value is referred to semianechoic chamber tests with boiler operating at max. heat output, with extension of flue gas exhaust system according to product standards.

MINI EOLO X 24 - Technical Data

Nominal heat input	kW (kcal/h)	25.6 (22051)
** DHW minimum heat input	kW (kcal/h)	8.3 (7117)
CH minimum heat input	kW (kcal/h)	10.5 (9057)
Nominal heat output (useful)	kW (kcal/h)	24.0 (20640)
** DHW minimum heat output (useful)	kW (kcal/h)	7.2 (6192)
CH minimum heat output (useful)	kW (kcal/h)	9.3 (7998)
Efficiency at nominal heat output	%	93.6
Efficiency at 30% nominal heat output load	%	90.3
Heat loss at case with burner On/Off	%	0.80 / 0.60
Heat loss at flue with burner On/Off	%	5.60 / 0.06
Central heating circuit max. operating pressure	bar	3
Central heating circuit max. operating temperature	°C	90
Adjustable central heating temperature	°C	35 - 85
System expansion vessel total volume	l	4
Heating expansion tank pre-charge	bar	1
Water content in generator	l	2.5
Total head available with 1000 l/h flow rate	kPa (m H ₂ O)	24.52 (2.5)
** Hot water production useful heat output	kW (kcal/h)	24.0 (20640)
** Domestic hot water adjustable temperature	°C	10 - 60
** Min. pressure (dynamic) domestic hot water circuit	bar	0.3
** Domestic hot water circuit max. working pressure	bar	10
*Specific capacity "D" UB Immergas 80 l (ΔT 30°C) according to EN 625	l/min	20.7
*Specific capacity "D" UB Immergas 105 l (ΔT 30°C) according to EN 625	l/min	24.4
*Specific capacity "D" UB Immergas 120 l (ΔT 30°C) according to EN 625	l/min	26.7
*Specific capacity "D" UB Immergas 200 l (ΔT 30°C) according to EN 625	l/min	35.1
Drawing capacity in continuous duty with UB Immergas (ΔT 30°C)	l/min	11.1
Weight of full boiler	kg	33.9
Weight of empty boiler	kg	31.4
Electrical connection	V/Hz	230/50
Power input	A	0.66
Installed electric power	W	130
Pump consumption	W	87.0
Fan consumption	W	35.0
Equipment electrical system protection	-	IPX5D
NO _x class	-	3
Weighted NO _x	mg/kWh	138
Weighted CO	mg/kWh	95
Type of appliance	C12 / C32 / C42 / C52 / C82 / B22 / B32	
Category	II2H3+	

- Flue temperature values refer to an air inlet temperature of 15°C.
- The data relevant to domestic hot water performance refers to a dynamic inlet pressure of 2 bar and an inlet temperature of 15°C; the values are measured directly at the boiler outlet considering that to obtain the data declared mixing with cold water is necessary.
- The max. sound level emitted during boiler operation is < 55dBA. The sound level value is referred to semianechoic chamber tests with boiler operating at max. heat output, with extension of flue gas exhaust system according to product standards.
- *Specific flow rate "D": domestic hot water flow rate corresponding to an average increase of 30K, which the boiler can supply in two successive withdrawals.
- ** When the boiler is connected to an external storage tank.

MINI EOLO 24 / MINI EOLO X 24 combustion parameters

		G20	G30	G31
Gas nozzle diameter	mm	1.35	0.79	0.79
Supply pressure	mbar (mm H ₂ O)	20 (204)	29 (296)	37 (377)
Flue flow rate at nominal heat output	kg/h	55	55	56
Flue flow rate at min heat output	kg/h	45	43	42
CO ₂ at Nom Q./Min.	%	6.65 / 2.50	7.70 / 3.00	7.50 / 3.10
CO with 0% O ₂ at Nom Q /Min.	ppm	92 / 80	137 / 95	90 / 80
NO _x with 0% O ₂ at Nom Q /Min.	mg/kWh	180 / 140	260 / 160	240 / 160
Flue temperature at nominal output	°C	101	103	101
Flue temperature at minimum output	°C	94	96	99

MINI EOLO 24 / MINI EOLO X 24 Variable thermal output

		METHANE (G20)			BUTANE (G30)			PROPANE (G31)			
HEAT OUTPUT (kW)	HEAT OUTPUT (kcal/h)		BURNER GAS FLOW RATE	PRESS. NOZZLES PRESSURE		BURNER GAS FLOW RATE	PRESS. NOZZLES PRESSURE		BURNER GAS FLOW RATE	PRESS. NOZZLES PRESSURE	
			(m ³ /h)	(mbar)	(mm H ₂ O)	(kg/h)	(mbar)	(mm H ₂ O)	(kg/h)	(mbar)	(mm H ₂ O)
24.0	20640	CH + D.H.W.	2.71	12.51	127.6	2.03	29.01	295.8	1.99	36.80	375.3
23.0	19780		2.60	11.53	117.6	1.94	26.65	271.7	1.91	34.07	347.4
22.0	18920		2.50	10.59	108.0	1.86	24.41	248.9	1.83	31.45	320.8
21.0	18060		2.39	9.70	99.0	1.78	22.29	227.3	1.75	28.95	295.2
20.0	17200		2.28	8.86	90.3	1.70	20.28	206.8	1.67	26.55	270.8
19.0	16340		2.17	8.06	82.2	1.62	18.38	187.5	1.59	24.26	247.4
18.0	15480		2.06	7.30	74.4	1.54	16.60	169.2	1.52	22.06	225.0
17.0	14620		1.96	6.58	67.1	1.46	14.92	152.1	1.44	19.97	203.7
16.0	13760		1.85	5.91	60.2	1.38	13.34	136.0	1.36	17.98	183.3
15.0	12900		1.74	5.27	53.7	1.30	11.87	121.1	1.28	16.08	163.9
14.0	12040		1.63	4.68	47.7	1.22	10.51	107.1	1.20	14.27	145.5
13.0	11180		1.52	4.12	42.0	1.14	9.24	94.3	1.12	12.56	128.1
12.0	10320		1.41	3.61	36.8	1.06	8.09	82.5	1.04	10.94	111.6
11.0	9460		1.30	3.13	31.9	0.97	7.03	71.7	0.96	9.42	96.0
10.0	8600		1.19	2.70	27.5	0.89	6.09	62.1	0.88	7.99	81.5
9.3	7998		1.11	2.42	24.7	0.83	5.49	56.0	0.82	7.05	71.8
8.0	6880		D.H.W.	0.97	1.96	20.0	0.72	4.52	46.1	0.71	5.42
7.2	6192	0.88		1.71	17.4	0.65	4.02	41.0	0.64	4.50	45.9

MINI EOLO 28 combustion parameters

		G20	G30	G31	G230
Gas nozzle diameter	mm	1.35	0.78	0.78	1.40
Supply pressure	mbar (mm H ₂ O)	20 (204)	29 (296)	37 (377)	20 (204)
Flue flow rate at nominal heat output	kg/h	60	59	60	67
Flue flow rate at min heat output	kg/h	64	67	66	68
CO ₂ at Nom Q./Min.	%	7.10 / 2.05	8.40 / 2.30	8.15 / 2.30	7.70 / 2.30
CO with 0% O ₂ at Nom Q /Min.	ppm	70 / 155	109 / 180	71 / 183	55 / 118
NO _x with 0% O ₂ at Nom Q /Min.	mg/kWh	157 / 102	269 / 125	220 / 125	176 / 118
Flue temperature at nominal output	°C	109	113	111	106
Flue temperature at minimum output	°C	77	79	76	73

Variable thermal output MINI EOLO 28

		METHANE (G20)			BUTANE (G30)			PROPANE (G31)			PROPANE AIR (G230)			
HEAT OUTPUT (kW)	HEAT OUTPUT (kcal/h)		BURNER GAS FLOW RATE		PRESS. NOZZLES PRESSURE		BURNER GAS FLOW RATE		PRESS. NOZZLES PRESSURE		BURNER GAS FLOW RATE		PRESS. NOZZLES PRESSURE	
			(m ³ /h)	(mbar)	(mm H ₂ O)	(kg/h)	(mbar)	(mm H ₂ O)	(kg/h)	(mbar)	(mm H ₂ O)	(m ³ /h)	(mbar)	(mm H ₂ O)
28.0	24080	CH + D.H.W.	3.14	11.50	117.3	2.35	28.00	285.5	2.31	36.00	367.1	2.44	12.20	124.4
27.0	23220		3.03	10.76	109.7	2.26	26.23	267.5	2.22	33.60	342.6	2.35	11.41	116.3
26.2	22516		2.94	10.17	103.7	2.19	24.84	253.3	2.16	31.71	323.4	2.28	10.79	110.0
25.0	21500		2.81	9.36	95.5	2.10	22.91	233.6	2.06	29.12	297.0	2.18	9.93	101.2
24.0	20640		2.70	8.71	88.8	2.02	21.34	217.6	1.98	27.04	275.7	2.09	9.23	94.1
23.0	19780		2.59	8.08	82.4	1.94	19.84	202.3	1.90	25.04	255.4	2.01	8.56	87.3
22.0	18920		2.49	7.48	76.3	1.86	18.39	187.5	1.83	23.14	236.0	1.93	7.92	80.8
21.0	18060		2.38	6.91	70.5	1.78	16.99	173.3	1.75	21.33	217.5	1.85	7.31	74.6
20.0	17200		2.27	6.36	64.8	1.70	15.65	159.6	1.67	19.59	199.8	1.76	6.72	68.6
19.0	16340		2.17	5.83	59.4	1.62	14.35	146.4	1.59	17.94	182.9	1.68	6.16	62.8
18.0	15480		2.06	5.32	54.3	1.54	13.11	133.6	1.52	16.36	166.8	1.60	5.62	57.3
17.0	14620		1.96	4.83	49.3	1.46	11.90	121.4	1.44	14.85	151.4	1.52	5.10	52.0
16.0	13760		1.85	4.37	44.5	1.38	10.74	109.5	1.36	13.41	136.8	1.44	4.60	46.9
15.0	12900		1.75	3.92	40.0	1.30	9.62	98.1	1.28	12.05	122.8	1.36	4.12	42.0
14.0	12040		1.64	3.49	35.6	1.23	8.54	87.1	1.21	10.75	109.6	1.27	3.66	37.3
13.0	11180		1.54	3.08	31.5	1.15	7.50	76.5	1.13	9.52	97.0	1.19	3.22	32.8
12.0	10320		1.43	2.69	27.5	1.07	6.50	66.3	1.05	8.35	85.2	1.11	2.80	28.5
11.2	9632		1.34	2.39	24.4	1.00	5.73	58.4	0.98	7.47	76.1	1.04	2.47	25.2
10.0	8600	1.21	1.97	20.1	0.90	4.61	47.0	0.89	6.22	63.4	0.94	2.01	20.5	
9.0	7740	1.10	1.63	16.6	0.82	3.72	37.9	0.81	5.25	53.6	0.85	1.65	16.8	
8.5	7310	1.04	1.47	15.0	0.78	3.29	33.5	0.77	4.80	48.9	0.81	1.48	15.0	

List of accessories and optionals

<p>Comando Amico Remoto V2 remote control (CAR^{V2}) code 3.021395</p>	<p>Comando Amico Remoto Universal remote control code 3.020946</p>
<p>External Probe code 3.014083</p>	<p>Antifreeze kit (up to -15°C) code 3.021474</p>
<p>Digital weekly chrono-thermostat code 3.014438</p>	<p>Radio chrono-thermostat (wireless) code 3.014439</p>
<p>Telephone control code 3.013305</p>	<p>GSM telephone control kit code 3.017182</p>
<p>Solar valve kit code 3.018911</p>	<p>Universal connection kit code 3.011667</p>
<p>Additional system expansion vessel kit (2 litres) code 3.018433</p>	<p>Polyphosphate dispenser kit code 3.016305</p>
<p>Mini Eolo 24 Top cover kit code 3.020897</p>	<p>Mini Eolo 28 Top cover kit code 3.020805</p>
<p>Separate storage tank unit coupling kit (only for MINI EOLO X 24) code 3.020934</p>	<p>Wall-mounted connection unit kit code 3.015229</p>

Troubleshooting

Before every intervention:

Check that the gas, water and electricity are correctly connected to the boiler, according to that indicated in the data plate and the instruction manual.

Also make sure that:

- the gas valve and boiler parameters are correctly adjusted;
- all devices outside the boiler function and are appropriately adjusted;
- the external and internal fuses are integral.

Before maintenance interventions or replacement of components, remove the electric power supply upstream from the appliance.

For correct use of the troubleshooting table, on intervention it is recommended to press the Reset button, switch the boiler off and remove voltage from the appliance for at least 5 seconds. This is to allow the boiler to start a new ignition cycle.

Ignition cycle

Apply voltage to the boiler.		
The display lights up. <i>Press the general button (🔌) to make sure that the boiler is not in OFF mode.</i>	No ▶	See section A

▼ Yes

The error 05 appears on the display	Yes ▶	See error section 05
The error 06 appears on the display	Yes ▶	See error section 06
The error 10 appears on the display	Yes ▶	See error section 10
The error 12 appears on the display	Yes ▶	See error 12 section (in case of connection to an external storage tank, X versions)
The error 15 appears on the display	Yes ▶	See error section 15
The error 24 appears on the display	Yes ▶	See error section 24
The error 37 appears on the display	Yes ▶	See error section 37

▼ No

CENTRAL HEATING MODE		
Press the general button until it reaches the winter position (🌸).		
Turn the heating set to maximum and suspend any DHW requests.		
The boiler pump starts. The (🌀) symbol is displayed.	▶	Check the presence of the TA jumper on clamps 40-41 of the P.C.B. <i>N.B.: the jumper must not be present when external devices are installed such as TA, remote control, clock programmer, etc...</i>
	No	Check the effective request from any external devices (TA/remote control/programmer clock). See error section 31.
	▶	See section B

▼ Yes

The 3-way valve goes into the CH position.	▶	See section C
--	---	----------------------

DOMESTIC HOT WATER MODE		
Press the general button until it reaches the summer position (🌞).		
Turn the DHW to maximum and open the cock.		
The (🔌) symbol is displayed.	▶	See section F
	No	
▼ Yes		
The pump starts.	▶	See section B
	No	
▼ Yes		
The 3-way valve goes into the DHW position.	▶	See section C
	No	

▼ Yes

The pump starts.	No ▶	The error 02 appears on the display	▶	See error section 02 - a
	No ▶	The error 11 appears on the display	▶	See error section 11
	No ▶	The error 03 appears on the display	▶	See error section 03 - a

▼ Yes

The error 20 appears on the display	Yes ▶	See error section 20
The error 03 appears on the display	Yes ▶	See error section 03 - b

▼ No

The ignition electrode make the spark.	No ▶	The error 01 appears on the display (wait for the P.C.B. to make 2 ignition cycles).	▶	See error section 01 - a
--	------	--	---	---------------------------------

▼ Yes

The burner ignites.	No ▶	The error 01 appears on the display (wait for the P.C.B. to make 2 ignition cycles).	▶	See error section 01 - b
	No ▶	The error 04 appears on the display (wait for the P.C.B. to run 5 ignition cycle attempts).	▶	See error section 04.

▼ Yes

The burner stays on after the first 10 seconds.	No ▶	The error 01 appears on the display (wait for the P.C.B. to run 2 ignition cycles).	▶	See error section 01 -c
---	------	---	---	-------------------------

▼ Yes

The error 27 appears on the display	Yes ▶	See error section 27		
The error 02 appears on the display	Yes ▶	See error section 02 - b		

▼ No

The boiler reaches and maintains the set central heating temperature.	▶ No	Check the Maximum heating output and adjust it to maximum if necessary.	▶	See section D
---	------	---	---	---------------

▼ Yes

The central heating request is satisfied.

The boiler reaches and maintains the set DHW temperature.	▶ No	See section D
	▶ No	Check that, - the flow rate of domestic hot water is not greater than the amount the boiler is able to supply (see technical data, output, flow rate, ΔT); - the plate heat exchanger is clean and replace it, if necessary.

▼ Yes

The domestic hot water request is satisfied.
--

Error codes

ERROR 01		No ignition block	
01 a	The ignition transformer discharges.	No ►	Replace the P.C.B.
	▼ Yes		
	The wiring between the ignition electrode and P.C.B. is OK.	No ►	Restore/replace the ignition electrode and relative wiring.
	▼ Yes		
Check the correct position and correct distance of the ignition electrode and replace it if necessary.			
01 b	There are 230 V DC on clamps 1-2 of the X1 connector <i>N.B.: measure the voltage within the safety time (8-10 s).</i>	No ►	Replace the P.C.B.
	▼ Yes		
	The connectors and relative wiring between gas valve and P.C.B. are OK.	No ►	Restore the electric connection/replace the wiring.
	▼ Yes		
	The main coils of the gas valve are OK.	No ►	Where possible, replace the main coils of the gas valve.
	▼ Yes		
The position and the distance of the ignition electrode with respect to the burner is OK.	No ►	Restore the position and the distance of the ignition electrode.	
	▼ Yes		
Replace the gas valve. <i>N.B.: before replacing the valve make sure that there is enough gas inlet dynamic pressure and that the gas valve is correctly calibrated.</i>			
01 c	The electrode detects a direct current of 6-8 µA during the burner ignition phase.	No ►	Replace the detection electrode and/or relative wiring.
	▼ Yes		
	Replace the P.C.B.		
ERROR 02		Over-heating safety thermostat block	
02 a	The wiring between the safety thermostat and P.C.B. is OK.	No ►	Restore the electric connection/replace the wiring.
	▼ Yes		
	Check/replace the safety thermostat. If the anomaly persists, replace the P.C.B.		
02 b	The safety thermostat functions regularly (intervention temperature higher than 100°C).	No ►	Replace the over-heating safety thermostat.
	▼ Yes		
	The boiler pump functions correctly. <i>N.B.: make sure that the pump functions at maximum speed.</i>	No ►	See section B
	▼ Yes		
	Any CH system zone valve or cut-off cocks are open.	No ►	Restore circulation in the CH system by acting on the closed devices and also check: - the correct positioning/functioning of the boiler by-pass; - the opening times of any zone valves (when necessary, it is possible to delay ignition of the burner by acting on the boiler "P8" parameter); - the correct functioning of any thermostatic valves.
	▼ Yes		
The NTC flow probe is OK (10 kΩ at 25°C).	No ►	Replace NTC probe.	
	▼ Yes		
Check/clean/replace the main heat exchanger.			

ERROR 03		Fan anomaly	
03 a	There are 220 VDC on clamps 3-4 of the X7 connector on the P.C.B.	No ▶	Replace the P.C.B.
	▼ Yes		
	230 V DC are present on the fan terminals.	No ▶	Restore the electric connection/replace the wiring.
	▼ Yes		
Replace the fan.			
03 b	The flue has been installed correctly.	No ▶	Clean/restore the correct operation of the flue. Check maximum lengths and any possible obstructions.
	▼ Yes		
	The silicone tube that connects the fan to the flue pressure switch is intact/clean.	No ▶	Restore/replace the silicone tube.
	▼ Yes		
Replace the fan. If the anomaly persists, replace the P.C.B.			

ERROR 04		Generic boiler P.C.B. anomaly	
04	The gas valve is operating correctly.	No ▶	Check the wiring of the electrical connection and make sure it is clean.
	▼ Yes		
	Replace the P.C.B. If the error continues check the quality of the power supply to exclude any external interference.		

ERROR 05		Flow probe anomaly	
05	The wiring between the flow probe and the board (connector X4 terminals 6-7) is OK.	No ▶	Restore the electric connection/replace the wiring.
	▼ Yes		
	Replace the NTC flow probe. If the anomaly persists, replace the P.C.B.		

ERROR 06		Domestic hot water probe anomaly	
06	The wiring between the DHW probe and the board (connector X2 terminals 4-5) is OK.	No ▶	Restore the electric connection/replace the wiring.
	▼ Yes		
	Replace DHW NTC probe. If the anomaly persists, replace the P.C.B.		

ERROR 10		Insufficient system pressure	
10	The boiler manometer displays a pressure exceeding 0.8 bar.	No ▶	Restore the correct pressure by acting on the system filling valve. <i>N.B.: in this case it is always advisable to ensure that there are no leaks in the central heating plant and check the correct factory-set value of the expansion vessel.</i>
	▼ Yes		
	The wiring between the absolute pressure switch and the board is OK.	No ▶	Restore the electric connection/replace the wiring.
	▼ Yes		
Check/replace the system pressure switch. If the anomaly persists, replace the P.C.B.			

ERROR 11		Flue pressure switch anomaly	
		This error occurs when the contact of the flue pressure switch is closed and the fan is at a standstill.	
11	The fan is at a standstill.	No ▶	Check the flue and make sure the chimney draught is working fine. <i>N.B.: the problem may be caused by an excessive residual draught in the chimney or by the presence of other extractors in the flue pipes.</i>
	▼ Yes		
	replace the flue pressure switch. If the anomaly persists, replace the P.C.B.		

ERROR 12		Storage tank probe anomaly <i>(in case of connection to an external storage tank, X versions)</i> The boiler prevents functioning in DHW mode but can function in CH mode.	
12	The wiring between the storage tank probe and the board (connector X2 terminals 6-7) is OK.	No ▶	Restore the electric connection/replace the wiring.
	▼ Yes		
	Replace the storage tank NTC probe. If the anomaly persists, replace the P.C.B.		

ERROR 15		Configuration error <i>N.B.: this P.C.B. can be used for instantaneous sealed chamber / open chamber boilers or with a storage tank. The board automatically recognises the type of boiler by means of the relative wiring of the P.C.B.</i>	
15	The P.C.B. is configured for instantaneous sealed chamber boilers.	No ▶	For MINI EOLO type boilers, check the following connections. - flue pressure switch wiring.
	▼ Yes		
	Replace the P.C.B.		

ERROR 20		Parasite flame block	
20	The detection electrode and the relative wiring are integral.	No ▶	Check/replace detection electrode/replace wiring.
	▼ Yes		
	Replace the P.C.B.		

ERROR 24		Push button control panel anomaly	
24	The buttons on the control panel function regularly (check that a "click" is heard when the button is pressed).	No ▶	Check that there are no keys blocked or jammed under the control panel.
	▼ Yes		
	Replace the P.C.B.		

ERROR 27		Insufficient circulation	
27	The boiler pump functions correctly. <i>N.B.: make sure that the pump functions at maximum speed.</i>	No ▶	See section B
	▼ Yes		
	Any CH system zone valve or cut-off cocks are open.	No ▶	Restore circulation in the CH system by acting on the closed devices and also check: - the correct positioning/functioning of the boiler by-pass; - the opening times of any zone valves (when necessary, it is possible to delay ignition of the burner by acting on the boiler "P8" parameter); - the correct functioning of any thermostatic valves.
	▼ Yes		
	The NTC flow probe is OK (10 kΩ at 25°C).	No ▶	Replace NTC probe.
	▼ Yes		
Check/clean/replace the main heat exchanger. If the anomaly persists, replace the P.C.B.			

ERROR 31		Loss of remote control communication	
31	The Remote Control is connected correctly. <i>N.B.: only remote controls supplied by Immergas can be used (CAR v2 o CAR Universal).</i>	No ►	Check the connection between P.C.B. (clamps 40-41) and remote control (IN+ and IN-) carried out respecting the polarity and using a dedicated line to prevent interference.
	▼ Yes		
	Replace the remote control. If the anomaly persists, replace the P.C.B.		
ERROR 37		Low power supply voltage	
37	The boiler power supply voltage exceeds 190 VDC.	No ►	Restore the correct electric power of the appliance (230 VDC ±10%).
	▼ Yes		
	The electric power supply connection wires and relative external fuses are integral.	No ►	Restore the electric connection/replace the cables/external fuses.
	▼ Yes		
Replace the P.C.B.			
ERROR 38		Loss of flame signal	
38	It is displayed every time the P.C.B., with the burner on, loses the flame signal. If normal conditions are restored, the boiler starts to run correctly again without having to be reset. If the error re-occurs 6 times in 8.5 minutes, the P.C.B. will display error 43 "Loss of continuous flame block".		
	Make sure that there are no combustion products inside the aspiration pipes, (no CO ₂); make sure the terminals, the joints and gasket seals for the flue are all in the correct position so as to avoid the re-circulation of combustion products inside the flue. Make sure the detection electrode is working correctly.		
ERROR 43		Block due to loss of continuous flame signal	
43	This will be displayed if error 38 occurs 6 times in 8.5 minutes. To eliminate the block, the Reset button (5) must be pressed. <i>See Error 38.</i>		

Sections

A	230 VDC are present on the L-N terminals of the P.C.B.	No ►	Check the electric power supply upstream from the boiler and restore it.
	▼ Yes		
	The P.C.B. fuse is integral.	No ►	See section E
	▼ Yes		
Replace the P.C.B.			

B	There are 230 VDC on clamps 1-2 of the X7 connector on the P.C.B.	No ►	Replace the P.C.B.
	▼ Yes		
	230 V DC are present on the pump clamps.	No ►	Restore the electric connection/replace the wiring.
	▼ Yes		
	The motor shaft turns freely.	No ►	Release the pump by acting on the shaft after having loosened the front cap.
	▼ Yes		
	The start-up condenser is integral.	No ►	Replace the condenser.
	▼ Yes		
Replace the pump.			

C	CENTRAL HEATING MODE: There are 230 VDC on clamps 1-3 of the X3 connector on the P.C.B.	No ►	
	DOMESTIC HOT WATER MODE: There are 230 VDC on clamps 1-2 of the X3 connector on the P.C.B.		
	▼ Yes		
	The wiring between the 3-way motor and the board is OK.	No ►	Restore the electric connection/replace the wiring.
	▼ Yes		
	The 3-way cartridge functions regularly (<i>it is not blocked</i>).	No ►	Release/replace the 3-way cartridge.
▼ Yes			
Replace 3-way valve motor.			

D	At least 20 V DC are present on the gas valve modulation coil cables. <i>N.B.: make the measurement by disconnecting the cables from the coil (see gas circuit chapter).</i>	No ►	Check wiring and replace the P.C.B. if necessary.
	▼ Yes		
	The gas valve modulation coil has a resistance of 20-25 Ohm (SIT 845). <i>N.B.: make the measurement by disconnecting the cables from the coil (see gas circuit chapter).</i>	No ►	Replace the gas valve.
	▼ Yes		
	The gas valve is calibrated correctly.	No ►	Adjust Minimum and Maximum values of the gas valve in agreement with that state din the instruction book.
	▼ Yes		
	The NTC flow probe is OK (10 kΩ at 25°C). In DHW functioning mode, also check the DHW NTC probe.	No ►	Replace NTC probe.
	▼ Yes		
Replace the P.C.B.			

E	The operations stated below are indispensable for checking the quality of the relay electric contacts positioned on the board.		
	Replace the fuses checking that there are no short circuited components (<i>pump, fan, gas valve, etc...</i>). Check safety device times and the complete power removal from the gas valve, operating as follows: - close the gas supply and make a function request; - check that, after 2 ignition attempts, the display shows error "01"; - with the help of the single wire wiring diagram, use a tester to check that there is no voltage on either power supply cables of the gas valve main coils (<i>see gas circuit chapter</i>).		

F	The flow (flow rate) of the DHW is at least 1.5 l/min.	No ▶	On the DHW system, check the correct opening of any cocks, cleanliness of the pipes, filters, flow rate limiters etc.
	▼ Yes		
	The flow switch functions correctly.	No ▶	Check/clean/replace the flow switch.
	▼ Yes		
	The wiring between the flow switch and the board is OK.	No ▶	Restore the electric connection/replace the wiring.
	▼ Yes		
Replace the P.C.B.			