

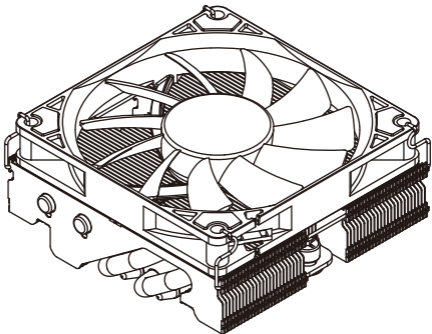

SILVERSTONE



Hydrogen H90 ARGB

High performance Small Form Factor CPU cooler

User manual

www.silverstonetek.com

Contents

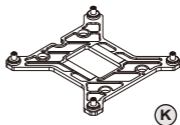
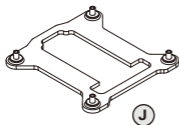
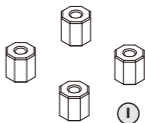
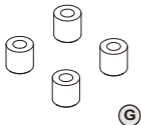
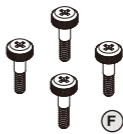
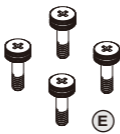
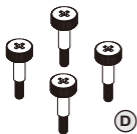
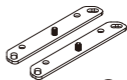
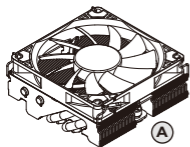

AMD

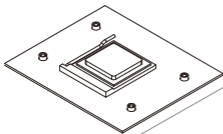
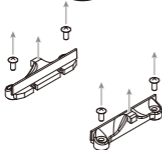

DE Bitte verwenden Sie die mit dem Motherboard gelieferte AMD-Backplate

FR Veuillez utiliser la plaque arrière AMD fournie avec la carte mère

ES Utilice la placa posterior AMD que viene con la placa base

IT Utilizzare la piastra posteriore AMD fornita con la scheda madre

RU Используйте заднюю панель AMD, поставляемую с материнской платой

TH โปรดใช้แผ่นรองหลังของ AMD ที่มาพร้อมกับเมนบอร์ด

JP マザーボードに付属のAMDバックプレートを使用してください

KR 마더 보드와 함께 제공되는 AMD 백플레이트를 사용하십시오

CN 请使用您主板上的AMD背板进行安装

TW 請使用您主機板上的AMD背板進行安裝

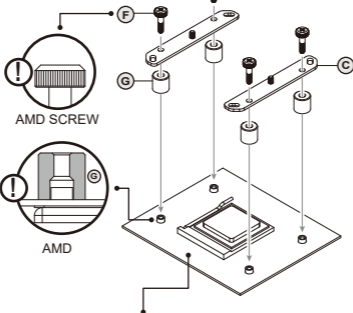

*Please use the AMD backplate comes with mainboard

INTEL

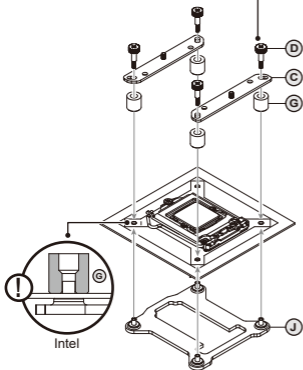

Intel LGA 115x / 1200

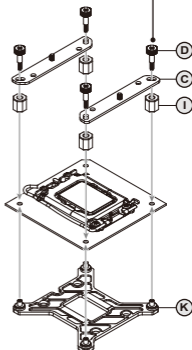

Intel LGA 1700

INTEL

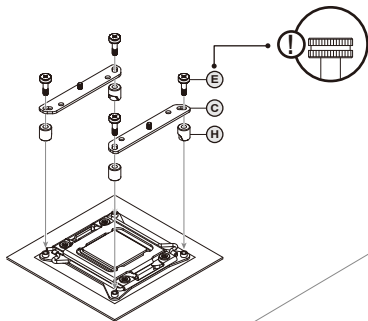

Intel LGA 2011 / 2066

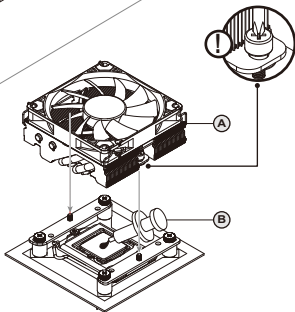

EN Please confirm the connector, the definition and direction of your pin header when connecting cables

Ensure ARGB controller / motherboard has same +5V pin definition as HYH90-ARGB

DE Bitte bestätigen Sie den Stecker, die Definition und Richtung Ihrer Stiftleiste beim Anschließen der Kabel

Stellen Sie sicher, dass ARGB-Controller / -Motherboard dieselbe +5-V-Pinbelegung hat wie HYH90-ARGB

FR Veuillez confirmer le connecteur, la définition et la direction de votre en-tête de broche lors de la connexion des câbles

Assurez-vous que le contrôleur ARGB/la carte mère a la même définition de broches +5 V que HYH90-ARGB

ES Confirme el conector, la definición y la dirección de su encabezado de pin al conectar los cables
Asegúrese de que el controlador / placa base ARGB tiene la misma configuración de pines +5V que el HYH90-ARGB

IT Confermare il connettore, la definizione e la direzione dell'intestazione del pin quando si collegano i cavi

Assicurarsi che il controller/la scheda madre ARGB abbia la stessa definizione di pin a +5 V dell'i HYH90-ARGB

RU Пожалуйста, подтвердите разъем, определение и направление вашего штыревого разъема при подключении кабелей

Убедитесь, что ARGB-контроллер/материнская плата имеет такое же определение контактов +5 В, что и HYH90-ARGB

TH โปรดยืนยันการเชื่อมต่อสายจำกัดความและทิศทางของส่วนหัวของขั้วเมื่อต่อสายเคเบิล
ตรวจสอบให้แน่ใจว่า คอนโทรลเลอร์ / เมนบอร์ด ARGB มีข้อกำหนดพิน +5V เดียวกับ HYH90-ARGB

JP ケーブルを接続するときは、コネクタ、ピンヘッドの定義と方向を確認してください

+5Vピン配列に関し、ARGBコントローラ/マザーボードがHYH90-ARGBと同一であることを確認してください

KR 케이블을 연결할 때 커넥터, 핀 헤더의 정의 및 방향을 확인하십시오

HYH90-ARGB처럼 ARGB 컨트롤러 / 마더보드가 동일한 +5V 핀 배열을 지원하는지 확인하여 주십시오

CN 在安装传输线时，请确认连接头定义、方向
确保ARGB控制器/主板的+5V pin定义与HYH90-ARGB相同

TW 在安装傳輸線時，請確認連接頭定義、方向
確保ARGB控制器/主板的+5V pin定義與HYH90-ARGB相同

