

FSP User Manual

Champ 1K/2K/3K Online UPS Tower/ Rack Mount

Uninterruptible Power Supply System

Version: 1.6

2. Installation and setup

NOTE: Before installation, please inspect the unit. Be sure that nothing inside the package is damaged. Please keep the original package in a safe place for future use.

2-1. Rear panel view

1K

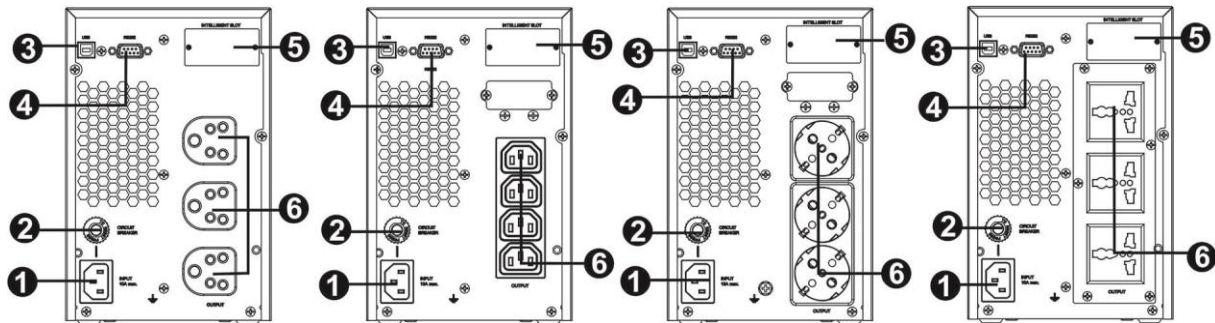

India Type

IEC Type

Schuko Type

Universal Type

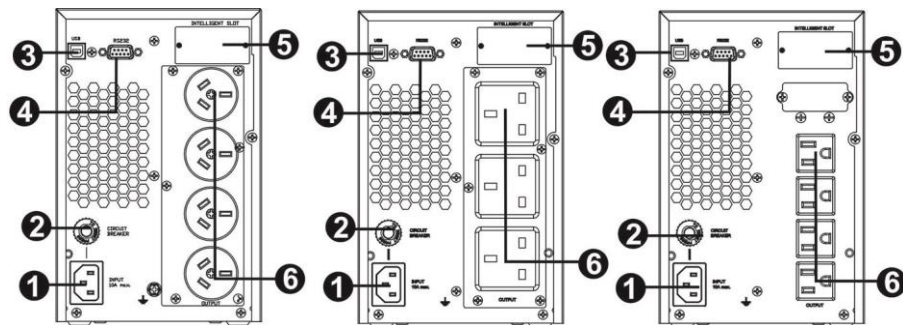

Argentina Type

UK Type

NEMA Type

2K

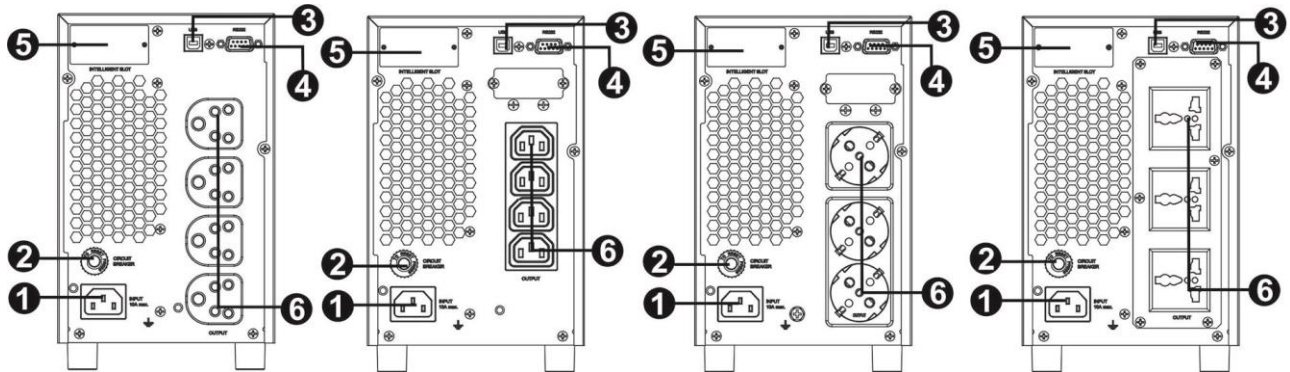

India Type

IEC Type

Schuko Type

Universal Type

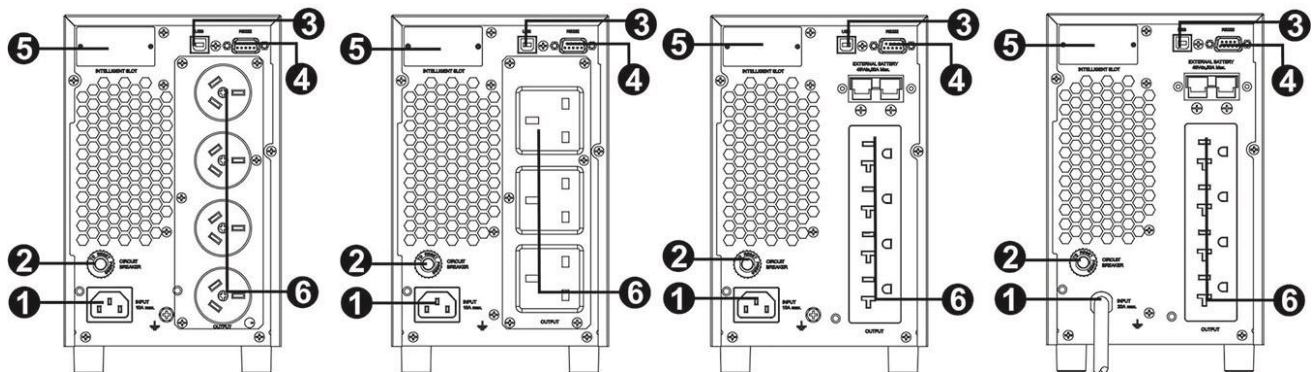

Argentina Type

UK Type

NEMA Type I

NEMA Type II

3K

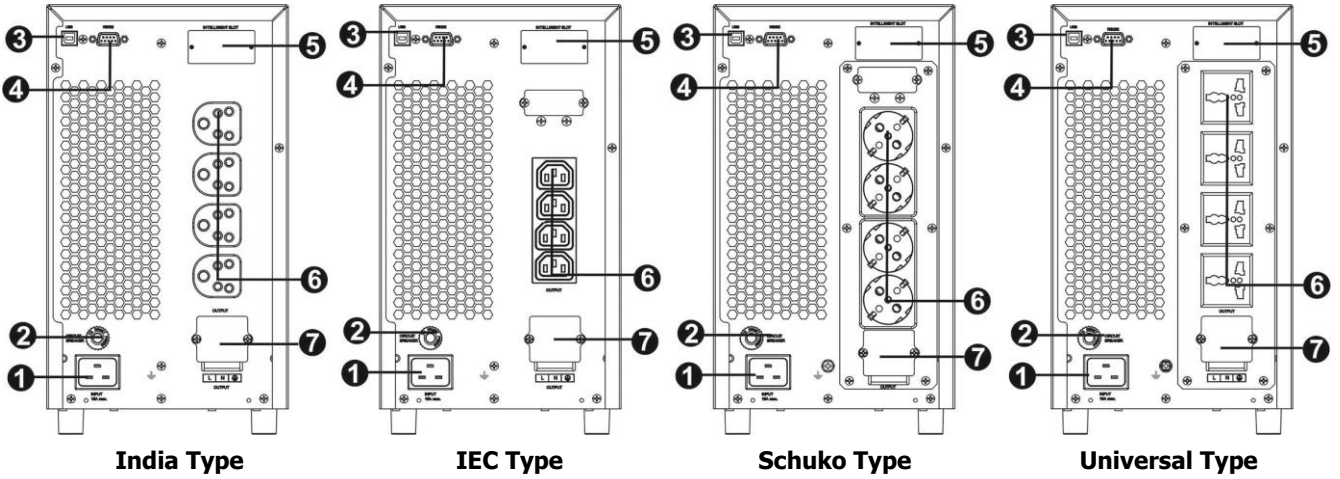

India Type

IEC Type

Schuko Type

Universal Type

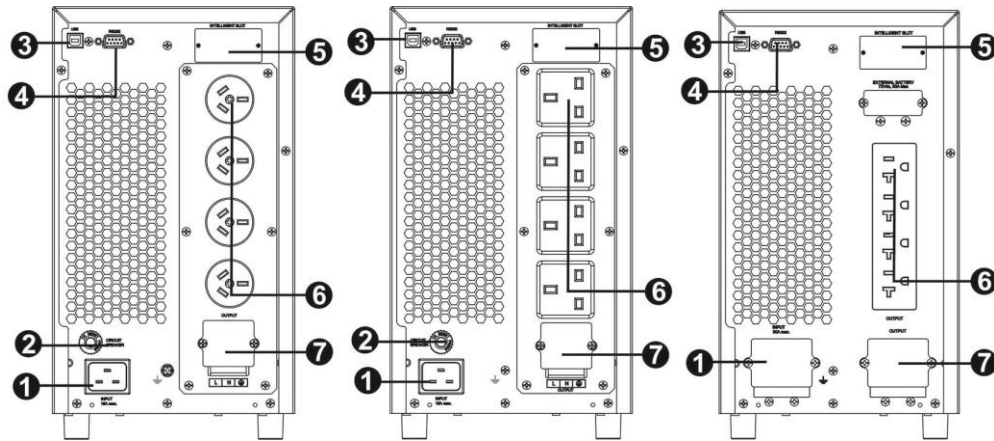

Argentina Type

UK Type

NEMA Type

1KR

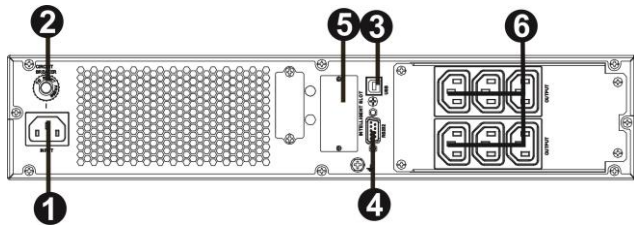

IEC Type

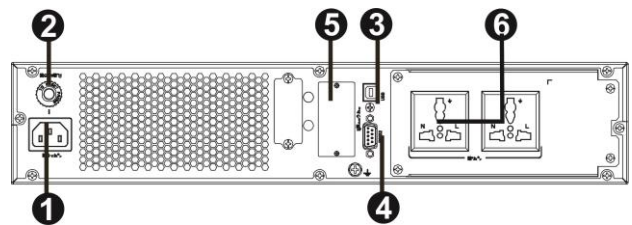

Universal Type

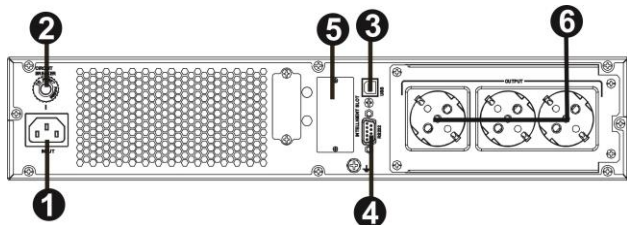

Schuko Type

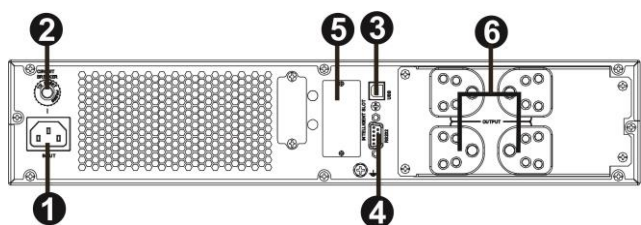

India Type

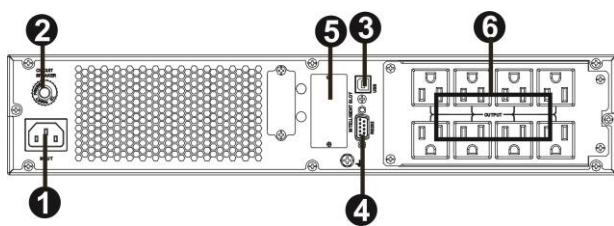

NEMA Type

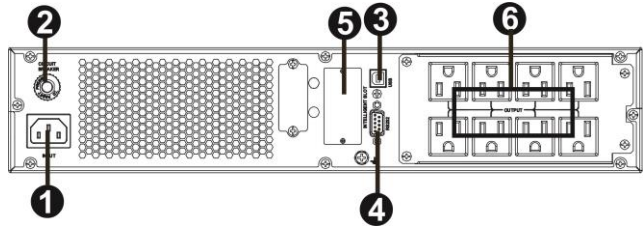

NEMA Type

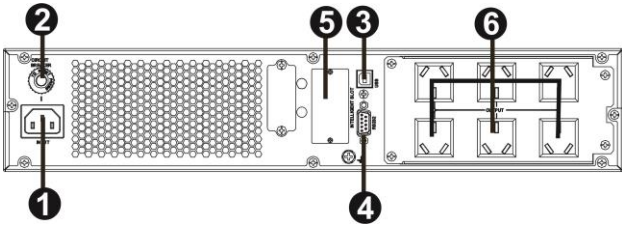

Argentina Type

2KR

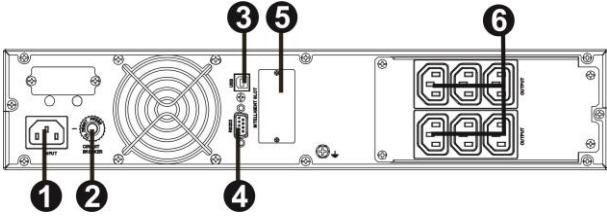

IEC Type

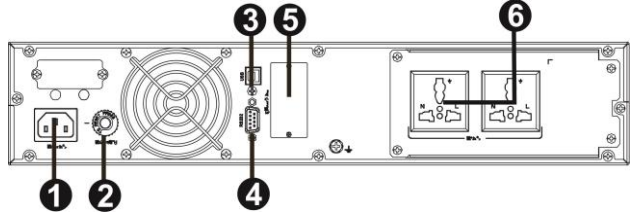

Universal Type

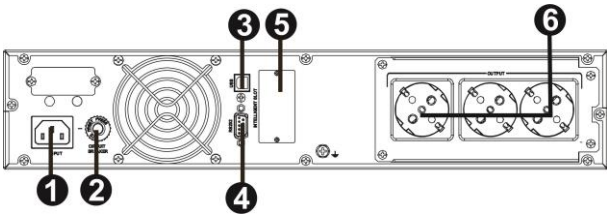

Schuko Type

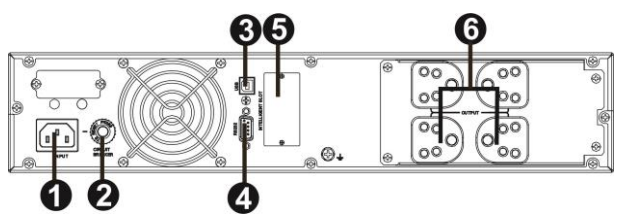

India Type

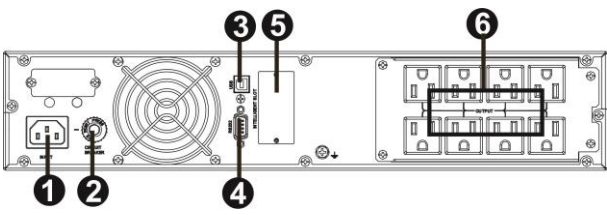

NEMA Type

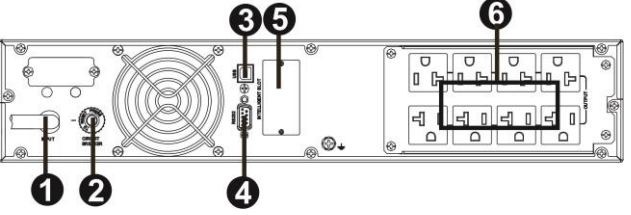

NEMA Type

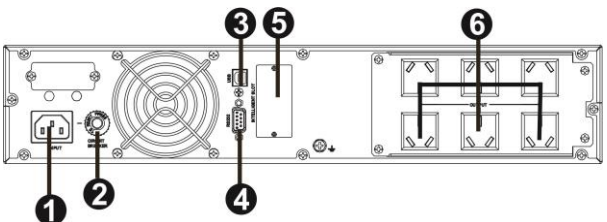

Argentina Type

3KR

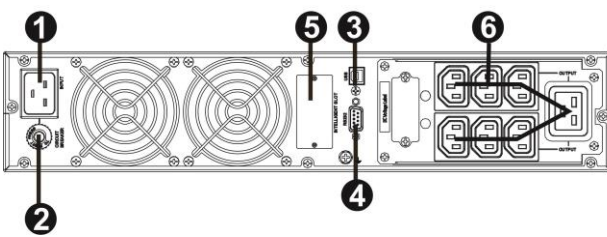

IEC Type

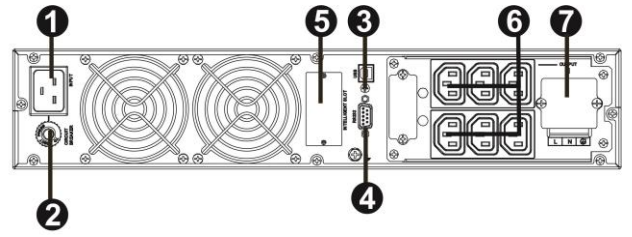

IEC Type

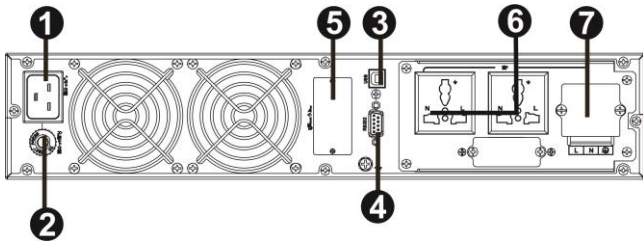

Universal Type

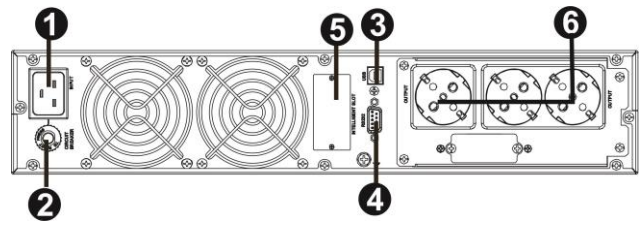

Schuko Type

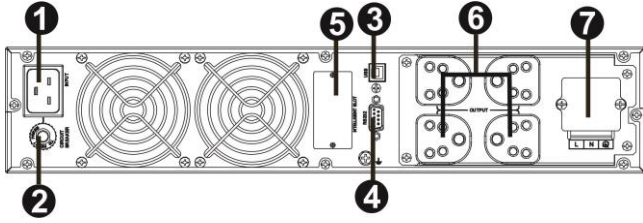

India Type

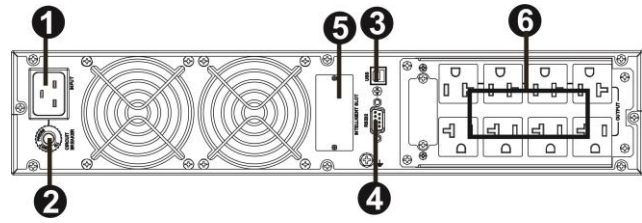

NEMA Type

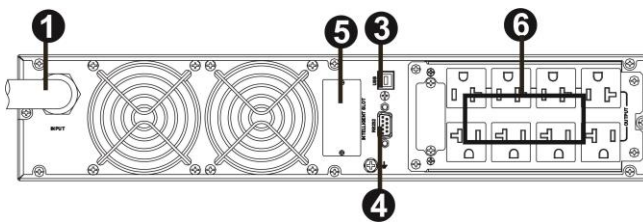

NEMA Type

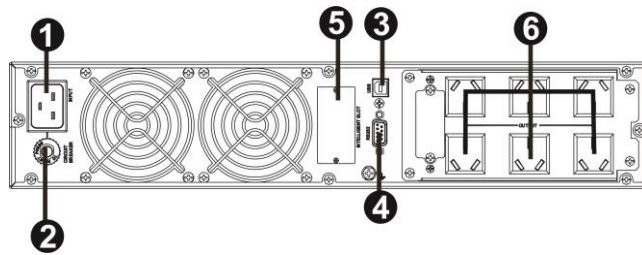

Argentina Type

1. AC input
2. Input circuit breaker
3. USB communication port
4. RS-232 communication port
5. SNMP intelligent slot (option)
6. Output receptacles
7. Output terminal

2-2. Operating principle

The operating principle of the UPS is shown as below

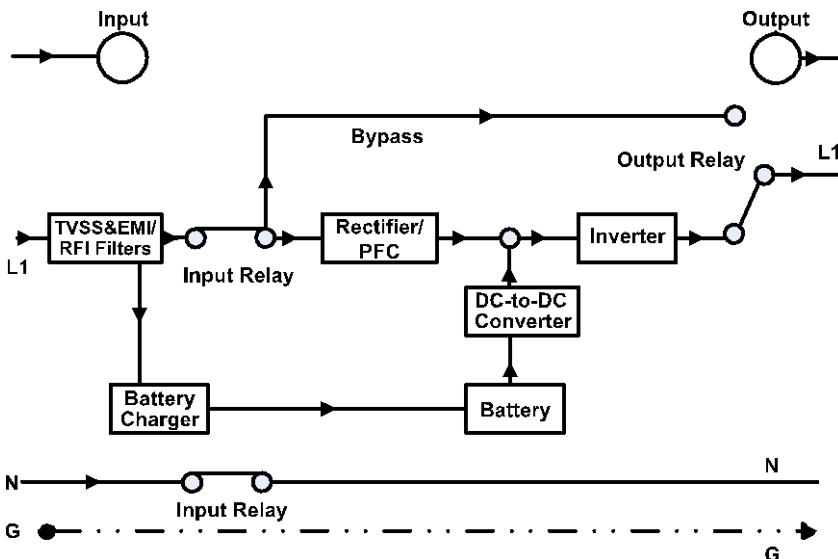

6. Specifications

MODEL		Champ 1K	Champ 2K	Champ 3K
CAPACITY*		1000 VA / 900 W	2000 VA / 1800 W	3000 VA / 2700 W
INPUT				
Voltage Range	Low Line Transfer	90Vac/80Vac/70Vac/60Vac±5% or 180Vac/160Vac/140Vac/120Vac±5% (Ambient Temp.<35°C) (based on load percentage 100% - 80 % / 80 % - 70 % / 70 - 60 % / 60 % - 0)		
	Low Line Comeback	100Vac/90Vac/80Vac/70Vac or 195Vac/175Vac/155Vac/135Vac ± 5 % (Ambient Temp.<35°C) (based on load percentage 100% - 80 % / 80 % - 70 % / 70 - 60 % / 60 % - 0)		
	High Line Transfer	145 Vac ± 5 % or 300 Vac ± 5 %		
	High Line Comeback	140 Vac ± 5 % or 290 Vac ± 5 %		
Frequency Range		40Hz ~ 70 Hz		
Phase		Single phase with ground		
Power Factor		≥ 0.99 @ nominal voltage (input voltage)		
OUTPUT				
Output voltage		110/115/120/127Vac or 208/220/230/240Vac		
AC Voltage Regulation		±1% (Batt. Mode)		
Frequency Range		47 ~ 53 Hz or 57 ~ 63 Hz (Synchronized Range)		
Frequency Range (Batt. Mode)		50 Hz ± 0.5% or 60Hz ± 0.5%		
Overload		Ambient Temp.<35°C 105%~110%: UPS shuts down after 10 minutes at battery mode or transfer to bypass when the utility is normal 110%~130%: UPS shuts down after 1minute at battery mode or transfer to bypass when the utility is normal >130%:UPS shuts down after 3 seconds at battery mode or transfer to bypass when the utility is normal		
Current Crest Ratio		3:1		
Harmonic Distortion		≤ 3 % THD (linear load); ≤ 6 % THD (non-linear load)		
Transfer Time	AC Mode to Batt. Mode	Zero		
	Inverter to Bypass	4 ms (Typical)		
Waveform (Batt. Mode)		Pure Sinewave		
EFFICIENCY				
AC Mode		88%	89%	90%
Battery Mode		83%	87%	88%
BATTERY				
Standard Model	Battery Type	12 V / 9 Ah		12 V / 9 Ah
	Numbers	2		4
	Recharge Time	4 hours recover to 90% capacity (Typical)		
	Charging Current	1.0 A (max.)		
Long-run Model*	Charging Voltage	27.4 Vdc ± 1%		54.7 Vdc ±1%
	Battery Numbers	2	3	4
	Charging Current	1.0A/2.0A/4.0A/6.0 A		
	Charging Voltage	27.4 Vdc ± 1%	41.0Vdc ± 1%	54.7 Vdc ±1%
PHYSICAL				
Standard Model	Dimension, D X W X H	282 X 145 X 220 (mm)		397 X 145 X 220 (mm)
	Net Weight (kgs)	9.8		17.0
Long-run Model*	Dimension, D X W X H	282 x 145 x 220 (mm)		397x 145 x 220(mm)
	Net Weight (kgs)	4.1	4.1	6.8
ENVIRONMENT				
Operation Humidity		20-90 % RH @ 0- 40°C (non-condensing)		
Noise Level		Less than 50dBA @ 1 Meter		
MANAGEMENT				
Smart RS-232 or USB		Supports Windows® 2000/2003/XP/Vista/2008/7/8, Linux, Unix and MAC		
Optional SNMP		Power management from SNMP manager and web browser		

*Long-run model is only available in 208/220/230/240VAC systems, PF will be adjust to 0.8

** Derate capacity to 80% of capacity in Frequency converter mode or when the output voltage is adjusted to 208VAC.

*** Product specifications are subject to change without further notice.

MODEL		Champ Rack 1K	Champ Rack 2K	Champ Rack 3K
CAPACITY*		1000 VA / 900 W	2000 VA / 1800 W	3000 VA / 2700 W
INPUT				
Voltage Range	Low Line Transfer	90Vac/80Vac/70Vac/60Vac±5% or 180Vac/160Vac/140Vac/120Vac±5% (Ambient Temp.<35°C) (based on load percentage 100% - 80 % / 80 % - 70 % / 70 - 60 % / 60 % - 0)		
	Low Line Comeback	100Vac/90Vac/80Vac/70Vac or 195Vac/175Vac/155Vac/135Vac ± 5 % (Ambient Temp.<35°C) (based on load percentage 100% - 80 % / 80 % - 70 % / 70 - 60 % / 60 % - 0)		
	High Line Transfer	145 Vac ± 5 % or 300 Vac ± 5 %		
	High Line Comeback	140 Vac ± 5 % or 290 Vac ± 5 %		
Frequency Range		40Hz ~ 70 Hz		
Phase		Single phase with ground		
Power Factor		≥ 0.99 @ nominal voltage (input voltage)		
OUTPUT				
Output voltage		110/115/120/127Vac or 208/220/230/240Vac		
AC Voltage Regulation		±1% (Batt. Mode)		
Frequency Range		47 ~ 53 Hz or 57 ~ 63 Hz (Synchronized Range)		
Frequency Range (Batt. Mode)		50 Hz ± 0.5% or 60Hz ± 0.5%		
Overload		Ambient Temp.<35°C 105%~110%: UPS shuts down after 10 minutes at battery mode or transfer to bypass when the utility is normal 110%~130%: UPS shuts down after 1minute at battery mode or transfer to bypass when the utility is normal >130%:UPS shuts down after 3 seconds at battery mode or transfer to bypass when the utility is normal		
Current Crest Ratio		3:1		
Harmonic Distortion		≤ 3 % THD (linear load); ≤ 6 % THD (non-linear load)		
Transfer Time	AC Mode to Batt. Mode	Zero		
	Inverter to Bypass	4 ms (Typical)		
Waveform (Batt. Mode)		Pure Sinewave		
EFFICIENCY				
AC Mode		88%	89%	90%
Battery Mode		83%	87%	88%
BATTERY				
Battery Type		12 V / 9 Ah	12 V / 9 Ah	12 V / 9 Ah
Numbers		2	4	6
Recharge Time		4 hours recover to 90% capacity (Typical)		
Charging Current		1.0 A (max.)		
Charging Voltage		27.4 Vdc ± 1%	54.7 Vdc ±1%	82.1 Vdc ±1%
PHYSICAL				
Dimension, D X W X H		310 x 438 x 88 mm	410 x 438 x 88 mm	630 x 438 x 88
Net Weight (kgs)		12	19	29.3
ENVIRONMENT				
Operation Humidity		20-90 % RH @ 0- 40°C (non-condensing)		
Noise Level		Less than 50dBA @ 1 Meter		
MANAGEMENT				
Smart RS-232 or USB		Supports Windows® 2000/2003/XP/Vista/2008/7/8, Linux, Unix and MAC		
Optional SNMP		Power management from SNMP manager and web browser		

* Derate capacity to 80% of capacity in Frequency converter mode or when the output voltage is adjusted to 208Vac.

** Product specifications are subject to change without further notice.