



CSC-109TX

HDMI/USB-C/VGA to HDMI/HDBaseT Scaler



Operation Manual



HDMI[®]
HIGH-DEFINITION MULTIMEDIA INTERFACE

The terms HDMI, HDMI High-Definition Multimedia Interface, and the HDMI Logo are trademarks or registered trademarks of HDMI Licensing Administrator, Inc.

DISCLAIMERS

The information in this manual has been carefully checked and is believed to be accurate. Cypress Technology assumes no responsibility for any infringements of patents or other rights of third parties which may result from its use.

Cypress Technology assumes no responsibility for any inaccuracies that may be contained in this document. Cypress also makes no commitment to update or to keep current the information contained in this document.

Cypress Technology reserves the right to make improvements to this document and/or product at any time and without notice.

COPYRIGHT NOTICE

No part of this document may be reproduced, transmitted, transcribed, stored in a retrieval system, or any of its part translated into any language or computer file, in any form or by any means—electronic, mechanical, magnetic, optical, chemical, manual, or otherwise—without express written permission and consent from Cypress Technology.

© Copyright 2018 by Cypress Technology.

All Rights Reserved.

TRADEMARK ACKNOWLEDGMENTS

All products or service names mentioned in this document are trademarks of the companies with which they are associated.



SAFETY PRECAUTIONS

Please read all instructions before attempting to unpack, install or operate this equipment and before connecting the power supply. Please keep the following in mind as you unpack and install this equipment:

- Always follow basic safety precautions to reduce the risk of fire, electrical shock and injury to persons.
- To prevent fire or shock hazard, do not expose the unit to rain, moisture or install this product near water.
- Never spill liquid of any kind on or into this product.
- Never push an object of any kind into this product through any openings or empty slots in the unit, as you may damage parts inside the unit.
- Do not attach the power supply cabling to building surfaces.
- Use only the supplied power supply unit (PSU). Do not use the PSU if it is damaged.
- Do not allow anything to rest on the power cabling or allow any weight to be placed upon it or any person walk on it.
- To protect the unit from overheating, do not block any vents or openings in the unit housing that provide ventilation and allow for sufficient space for air to circulate around the unit.
- Please completely disconnect the power when the unit is not in use to avoid wasting electricity.

VERSION HISTORY

REV.	DATE	SUMMARY OF CHANGE
RDV1	2021/04/20	Preliminary release



CONTENTS

1. Introduction	1
2. Applications	1
3. Package Contents	2
4. System Requirements	2
5. Features	3
6. Operation Controls and Functions	4
6.1 Front Panel.....	4
6.2 Rear Panel.....	5
6.3 Remote Control	7
6.4 IR Cable Pinouts.....	8
6.5 RS-232 Pinout and Defaults	8
6.6 OSD Menu.....	9
6.7 WebGUI Control	26
6.7.1 Status and Video Tab	28
6.7.2 Audio and System Tab.....	31
6.8 Telnet Control	36
6.9 Serial and Telnet Commands	36
7. Connection Diagram	59
8. Specifications	60
8.1 Technical Specifications	60
8.2 Video Specifications	61
8.3 Audio Specifications	63
8.3.1 Digital Audio	63
8.3.2 Analog Audio	63
8.4 Cable Specifications	64
8.5 HDBaseT Features.....	65
9. Acronyms	66



1. INTRODUCTION

This 5 by 2 multi-format scaling switcher provides HDMI, USB-C, HDBaseT, and VGA inputs which can be freely selected for output at a scaled resolution of the user's choosing over the mirrored HDMI and HDBaseT outputs. The HDMI and USB-C ports support resolutions up to 4K@60 (4:4:4, 8-bit) while the HDBaseT output supports automatic color subsampling of 4K50/60(4:4:4) sources to 4K50/60(4:2:0). The VGA inputs support resolutions up to WUXGA. The HDBaseT output provides a great solution to extend your audio and video up to 100 meters over a single run of Cat.6A cable as well as providing PoH power to compatible HDBaseT transmitters and receivers.

This unit also includes multiple analog stereo audio inputs and a microphone input (with support for optional 48V phantom power) along with an analog stereo output to provide a range of audio routing and mixing flexibility. The included audio DSP engine also provides auto-gain functionality, allowing for the mic source to be mixed with the audio from one of the video sources while reducing the background audio level in order to enhance the primary audio source. The ability to switch back and forth between mixed and non-mixed audio greatly simplifies the presentation experience.

A trigger input interface is also provided to allow the easy addition of a remote control keypad, or other trigger-supporting products, which can be installed within a podium or within a table in a conference room or classroom. This interface can allow the user to activate functions with the simple press of a button. Standard control is available via front panel buttons with an OSD, WebGUI, Telnet, and RS-232 making it exceptionally versatile.

2. APPLICATIONS

- Analog and digital source integration
- Upscaling low resolution video for high-definition displays
- Conference centers
- Lecture halls
- Schools and universities

3. PACKAGE CONTENTS

- 1× HDMI/USB-C/VGA to HDMI/HDBaseT Scaler
- 1× 24V/5A DC Power Adapter
- 1× Remote Control (CR-192)
- 1× IR Blaster Cable
- 1× IR Extender Cable
- 1× 3.5mm to 9-pin D-sub Male Cable
- 1× 6-pin Terminal Block
- 1× Shockproof Feet (Set of 4)
- 1× Operation Manual

4. SYSTEM REQUIREMENTS

- HDMI/USB-C source equipment such as media players, video game consoles, or set-top boxes.
- VGA source equipment such as PCs, laptops, or set-top boxes.
- HDMI receiving equipment such as an HDTV, monitor, or audio amplifier.
- Analog audio receiving equipment such as headphones, an audio amplifier, or powered speakers.
- A compatible HDBaseT receiver with PoH support is recommended.
- The use of Premium High Speed HDMI cables, and industry standard Cat.6, Cat.6A, or Cat.7 Ethernet cable is highly recommended.

5. FEATURES

- HDMI 2.0 and DVI 1.0 compliant
- HDCP 1.x and 2.2 compliant
- 5 video inputs (2×HDMI, 1×USB-C, 2×VGA)
- 2 mirrored video outputs (1×HDMI, 1×HDBaseT)
- Supports switching and scaling of all AV inputs for display over the mirrored HDMI and HDBaseT outputs
- Supports up to 4K UHD (18Gbps, 4K@50/60Hz 4:4:4, 8-bit) digital video input (HDMI, USB-C) and output (HDMI)
- VGA input supports resolutions up to 1080p60/WUXGA (RB)
- HDBaseT output supports resolutions up to 4K@60Hz (4:2:0, 8-bit) or 4K@30Hz (4:4:4, 8-bit). 4K@50/60Hz (4:4:4, 8-bit) output will be automatically color space converted to fit within the available bandwidth
- HDBaseT output extends video, audio, and data over a single Cat.5e/6/7 cable and can reach distances up to 100m/328ft at 4K when using Cat.6a/7
- HDBaseT feature support: HD Video & Audio, 100BaseT Ethernet, PoH(PSE), and Control (Bi-directional IR/RS-232 pass-through)
- Supports pass-through of LPCM 2.0 digital audio
- Supports embedding any analog audio source with any video source
- Audio mixer function allows the mixing of audio from any LPCM 2.0 audio source with the microphone input with auto-gain functionality
- Trigger input block supports direct input selection
- IR remote control provides discrete input source selection
- USB Type-C port provides up to 60W of power to connected devices
- Provides PoH (PSE) from the HDBaseT output to power a connected HDBaseT (PD) receiver (compatible receivers only)
- Comprehensive EDID and HDCP management
- Controllable via front panel controls with OSD, RS-232, Telnet, WebGUI, and triggers

6. OPERATION CONTROLS AND FUNCTIONS

6.1 Front Panel

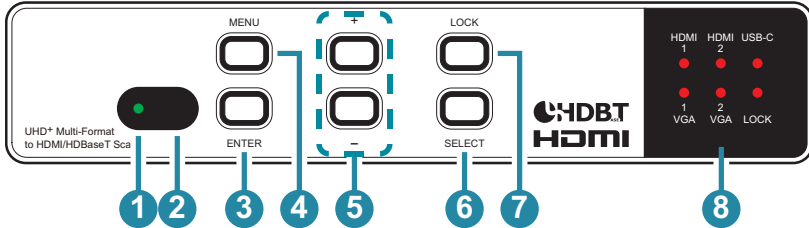

- 1 **POWER LED:** This LED will illuminate to indicate the unit is on and receiving power.
- 2 **IR Window:** Accepts IR signals from the included IR remote for control of this unit only.
- 3 **ENTER Button:** Press to confirm a selection within the OSD or to go deeper into a menu item.
- 4 **MENU Button:** Press to enter the OSD menu, or to back out from menu items.
- 5 **-/+ (MINUS/PLUS) Buttons:** Press to move up and down or adjust selections within OSD menus.
Note: Pressing "Menu" and "+" together will reset the output resolution to XGA@60Hz (1024×768). Pressing "Menu" and "-" together will reset the output resolution to 1080p@60Hz.
- 6 **SELECT Button:** Press this button to sequentially switch through the available inputs.
- 7 **LOCK Button:** Press and hold for 3 seconds to lock all button functions on the front panel. Press and hold for 3 seconds again to release the lock function. The "LOCK" LED will be lit when the front panel is in the locked state.
- 8 **Input & Status LEDs:** These LEDs indicate the currently selected source as well as the current front panel lock state.

6.2 Rear Panel

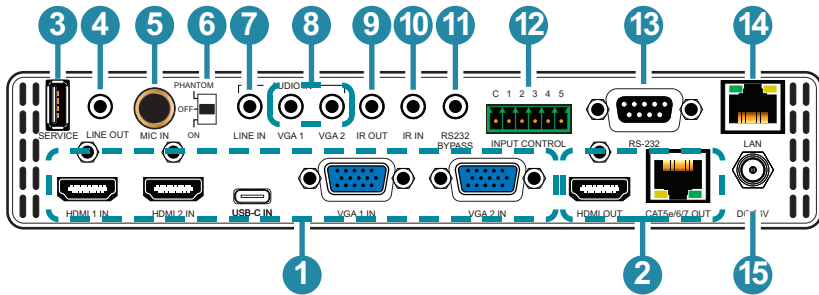

- HDMI 1~2 IN Ports:** Connect to HDMI source equipment such as media players, game consoles, or set-top boxes. DVI sources are supported with the use of an HDMI to DVI adapter.

USB-C IN Port: Connect to USB Type-C source equipment such as a PC or laptop. Can provide up to 60W of power to the connected device.

Note: Not all devices with USB Type-C ports can support video output. Please verify that the intended device supports video output from the USB Type-C port before connecting it.

VGA 1~2 IN Ports: Connect to VGA source equipment such as a PC or laptop. YUV sources, such as DVD players, are also supported with the use of a 15-pin to 3-RCA adapter.

- HDMI OUT Port:** Connect to an HDMI TV, monitor, or amplifier for digital video and audio output.

CAT5e/6/7 OUT Port: Connect to a compatible HDBaseT receiver with a single Cat.5e/6/7 cable for transmission of all data signals. PoH will also be supplied to a connected compatible PD receiver.

- SERVICE Port:** This slot is reserved for firmware update use only.
- LINE OUT Port:** Connect to powered speakers or an amplifier for stereo analog audio output.
- MIC IN Port:** Connect to a standard microphone using a 6.35mm plug. Phantom power mics are supported.
- PHANTOM/OFF/ON Switch:** Set the switch to “ON” for standard condenser mics (5V) or “PHANTOM” for professional (48V) phantom power mics. Set the switch to “OFF” for mics that don’t require additional power.

- 7 **LINE IN Port:** Connect to the stereo analog output of a device such as a CD player or PC.
- 8 **VGA 1~2 Ports:** Connect to the stereo analog output of the device connected to the associated VGA input port.
- 9 **IR OUT Port:** Connect to an IR Blaster to transmit IR signals from the other end of the HDBaseT connection to devices within direct line-of-sight of the IR Blaster.
- 10 **IR IN Port:** Connect to an IR Extender to receive local IR control signals and extend them to devices connected to the other end of the HDBaseT connection. Ensure that the remote being used is within direct line-of-sight of the IR Extender.
- 11 **RS-232 BYPASS Port:** Connect to a PC, laptop, or serial controllable device with a 3.5mm adapter cable for the extension of RS-232 signals between both ends of the HDBaseT connection.
- 12 **INPUT CONTROL 6-pin Terminal Block:** This terminal block is used for direct source input selection. Short the ground pin (marked as "C") with any one of the following 5 pins to make individual source selections.

Note: The pin assignments can be changed within the WebGUI. By default, the pins are assigned as follows:

Default Trigger Assignment	
Pin 1	HDMI 1 IN
Pin 2	HDMI 2 IN
Pin 3	USB-C IN
Pin 4	VGA 1 IN
Pin 5	VGA 2 IN

- 13 **RS-232 Port:** Connect directly to a PC, laptop, or other serial control device to send RS-232 commands to control the unit.
- 14 **LAN Port:** Connect directly, or through a network switch, to your PC/ laptop to control the unit via Telnet/WebGUI and to extend the network across the HDBaseT connection.
- 15 **DC 24V Port:** Plug the 24V DC power adapter into this port and connect it to an AC wall outlet for power.

6.3 Remote Control

- 1 HDMI 1~2, USB-C & VGA 1~2:**
Press any of these buttons to switch immediately to the corresponding input.
- 2 MENU:** Access the OSD menu.
- 3 EXIT:** Exit the OSD menu.
- 4 ▲/▼:** Navigate up/down within the OSD menu items.
◀/▶ & VOL -/+: Adjust the selected item's parameters (+) or (-) within the OSD menu or adjust output volume.
OK: Confirm your selections within the OSD menu.
- 5 AUTO ADJUST:** Automatically adjust and center analog PC sources.
- 6 RESET:** Return to factory default settings.

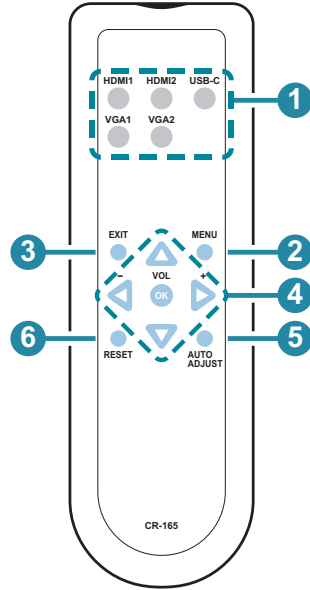

6.4 IR Cable Pinouts

IR Blaster Cable

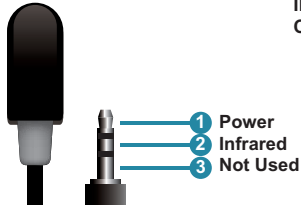

IR Extender Cable

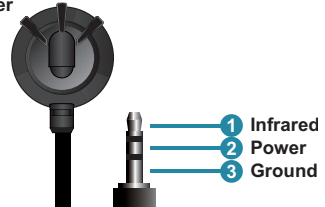

6.5 RS-232 Pinout and Defaults

Serial Port Default Settings	
Baud Rate	19200
Data Bits	8
Parity Bits	None
Stop Bits	1
Flow Control	None

RS-232 (Control)

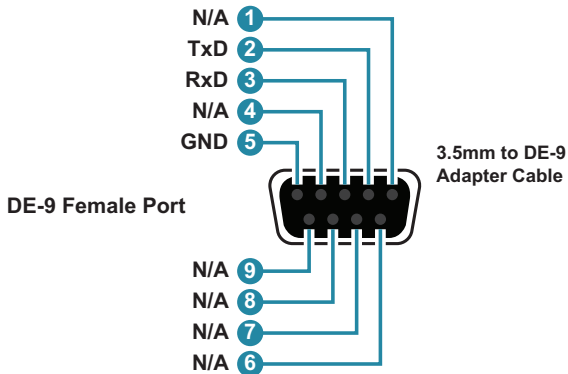

RS-232 (Bypass)

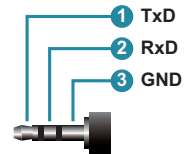

6.6 OSD Menu

All functions of this unit can be controlled by using the OSD (On Screen Display) which is activated by pressing the MENU button on the front of the unit. Use the + (PLUS), - (MINUS), and ENTER buttons to navigate the OSD menu. Press the MENU button to back out from any menu item and then press it again to close the menu.

MAIN MENU
Video
Picture
Audio
OSD
Ethernet
EDID
System
Factory
Information

The individual functions of the OSD will be introduced in the following section. Items marked in **BOLD** are the factory default settings.

VIDEO		
2ND LEVEL	3RD LEVEL	4TH LEVEL
Output Routing	HDMI 1	
	HDMI 2	
	USB-C	
	VGA 1	
	VGA 2	
Output Resolution	NATIVE HDMI	
	Native HDBT	
	640×480 60	
	800×600 60	
	1024×768 60	
	1280×768 60	
	1280×800 60	
	1280×1024 60	
	1360×768 60	
	1400×1050 60	
	1440×900 60	
	1600×1200 60	
	1680×1050 60	
	1920×1200 60 RB	
	2560×1600 60 RB	
	1920×1080 60	
	1280×720 60	
	2048×1080 50	
	2040×1080 60	
	2560×1440 60 RB	
720×480p 60		
1280×720p 60		
1920×1080p 60		

VIDEO		
2ND LEVEL	3RD LEVEL	4TH LEVEL
	720×576p 50	
	1280×720p 50	
	1920×1080p 50	
	1920×1080p 24	
	1920×1080p 25	
	1920×1080p 30	
	2560×1080p 50	
	2560×1080p 60	
	3840×2160p 24	
	3840×2160p 25	
	3840×2160p 30	
	3840×2160p 50	
	3840×2160p 60	
	4096×2160p 24	
	4096×2160p 25	
	4096×2160p 30	
	4096×2160p 50	
	4096×2160p 60	
Aspect	FULL	
	Best Fit	
	Pan Scan	
	Letterbox	
	Under 2	
	Under 1	
	Follow In	
	Over Scan	

VIDEO		
2ND LEVEL	3RD LEVEL	4TH LEVEL
No Signal Color	BLACK	
	White	
	Blue	
	Red	
	Green	
Blank	OFF	
	On	
Freeze	OFF	
	On	
Auto Setting	Auto Sync Off	
		30s
		60s
		3 min
		5 min
	10 min	
	Auto Video Routing	AUTO SWITCH
	Off	
HDCP Setting	HDMI 1 HDCP	Support Off
		Refer to Source
		REFER TO DISPLAY
	HDMI 2 HDCP	Support Off
		Refer to Source
		REFER TO DISPLAY
	USB-C HDCP	Support Off
		Refer To Source
		REFER TO DISPLAY

VIDEO		
2ND LEVEL	3RD LEVEL	4TH LEVEL
PC Setting	PC Auto Setup	Execute
	PC H Position	0~250
	PC V Position	0~250
	PC Phase	0~250
	PC Clock	0~255
	PC Reset	

- 1) **Output Routing:** Select the video input to route to both outputs.
- 2) **Output Resolution:** Select the output resolution to use. Selecting a "Native" resolution option will make the unit automatically select an output resolution based on the detected EDID of the connected display.
Note: 4K@50/60Hz (4:4:4, 8-bit) output resolutions will be automatically color space converted to 4K@50/60 (4:2:0, 8-bit) when output over HDBaseT.
- 3) **Aspect:** Select the aspect ratio to use when outputting the source. "Full" stretches the source to fill the output resolution, regardless of the original aspect ratio, while "Best Fit" will always attempt to retain the original source's correct aspect ratio by adding black bars if necessary. "Follow In" centers the source on the screen, without any scaling (1:1 pixel reproduction).
- 4) **No Signal Color:** select the full screen color to display when there is no signal.
- 5) **Blank:** Enable or disable blanking the video output.
- 6) **Freeze:** Enable or disable freezing the video output.
- 7) **Auto Setting:**
 - **Auto Sync Off:** Sets the amount of time to continue outputting sync with the "no signal color" if there is no live source and no operations have been executed on the unit. Setting this to "OFF" forces the unit to always output sync.
 - **Auto Video Routing:** Enable or disable automatically switching to any newly detected source.

- 8) **HDCP Setting:** Provides control over the HDCP behavior of each input.
- 9) **PC SETTING:** This menu is only available when a VGA source is active.
 - **PC Auto:** Provides a way to manually activate the auto detection of the VGA source's signal parameters. Press "Enter" to activate.

Note: For best results, a VGA source with a bright image that extends to all 4 edges of the screen should be displayed when this is activated.
 - **PC H/V Position:** Set the horizontal and vertical position of the current VGA input's signal.
 - **PC Phase:** Set the PC phase setting for the current VGA input.
 - **PC Clock:** Set the PC clock setting for the current VGA input.
 - **PC Reset:** Reset all PC picture settings back to their factory defaults.

PICTURE	
2ND LEVEL	3RD LEVEL
Color Gain R	0~1023 (512)
Color Gain G	0~1023 (512)
Color Gain B	0~1023 (512)
Color Offset R	0~1023 (512)
Color Offset G	0~1023 (512)
Color Offset B	0~1023 (512)
Brightness	0~60 (30)
Contrast	0~60 (30)
Hue	0~60 (30)
Saturation	0~60 (30)
Sharpness	0~63 (0)
NR	OFF
	Low
	Middle
	High
	Auto
Reset Picture	

- 1) **Color Gain R/G/B:** Set the red, green, and blue color gain level of the scaled output.
- 2) **Color Offset R/G/B:** Set the red, green, and blue color offset level of the scaled output.
- 3) **Brightness/Contrast:** Set the overall brightness and contrast of the scaled output image.
- 4) **Hue:** Set the hue shift of the scaled output image.
- 5) **Saturation:** Set the color saturation level of the scaled output image.
- 6) **Sharpness:** Set the amount of sharpness processing to apply to the scaled output image.
- 7) **NR:** Set the aggressiveness of the digital noise reduction processing when applied to the scaled output image. Selecting "Off" disables all noise reduction processing.
- 8) **Reset Picture:** Reset all picture settings back to their factory defaults.

AUDIO		
2ND LEVEL	3RD LEVEL	4TH LEVEL
Audio Routing	Follow User	
	FOLLOW VIDEO	
	Line	
	VGA 1	
	VGA 2	
Follow User Setting	Audio On HDMI 1	EMBEDDED
		Line
		VGA 1
		VGA 2
	Audio On HDMI 2	[Same options as HDMI 1]
	Audio On USB-C	[Same options as HDMI 1]
	Audio On VGA 1	Line
		VGA 1
		VGA 2
	Audio On VGA 2	Line
		VGA 1
		VGA 2
	Reset Follow User Setting	
Talk Over Setting	Talk Over	ON
		Off
	Depth	0~100% (100)
	Trigger Threshold	-100~0db (-70db)
	Trigger Time	0~20.0s (1.0s)
	Attack Time	0~20.0s (1.0s)

AUDIO		
2ND LEVEL	3RD LEVEL	4TH LEVEL
	Hold Time	0~20.0s (2.0s)
	Release Time	0~20.0s (3.0s)
	Reset Talk Over	
Output Mixer	OFF	
	On	
	Mic Only	
Volume On Mic Gain	0~100 (80)	
Volume On HDMI/ HDBT Out	0~100 (80)	
Volume On Analog Out	0~100 (80)	
Mute On HDMI/HDBT Out	OFF	
	On	
Mute On Analog Out	OFF	
	On	
Delay On HDMI/HDBT Out	OFF	
	10~200ms	
Delay On Analog Out	OFF	
	10~200ms	
Reset Audio		

- 1) **Audio Routing:** Set the audio routing behavior of the unit.
 - **Follow User:** Audio routing will follow the individual audio routing selections made for each source in the “Follow User Setting” section.
 - **Follow Video:** All digital sources will use their native embedded audio content. The VGA sources will use the associated VGA 1~2 audio inputs.
 - **Line/VGA 1/VGA 2:** Forces the audio output to always use the selected analog audio source.
- 2) **Follow User Setting:** Set the preferred audio routing to use for each source when “Follow User” is active. Select the preferred “Follow User” source for each input. Select “Reset Follow User Setting” to reset all follow user settings back to their factory defaults.

3) **Talk Over Setting:** Set the automatic background audio level behavior to use when the mixer is active and “Talk Over” mode is enabled.

- **Talk Over:** Enable or disable the use of the unit’s Talk Over mode which allows finer control over how the microphone input is handled while mixing sources.

Note: When Talk Over mode is disabled, or the mixer is disabled, the below settings will have no effect.

- **Depth:** Sets the amount the primary audio source’s volume level will be decreased when the Talk Over feature is triggered. The available adjustment range is 0 to 100%.
- **Trigger Threshold:** Set the microphone’s signal detection threshold. The Talk Over will be activated when the microphone’s signal is over the threshold and lasting longer than the trigger time. The available adjustment range is -100dB to 0dB.
- **Trigger Time:** Set the length of time a signal must be over the current signal detection threshold in order to trigger the microphone Talk Over function. The available adjustment range is 0 to 20 seconds.
- **Attack Time:** Set the mixer attack time, the length of time used fading the microphone’s audio into the output mix. The available adjustment range is 0 to 20 seconds.
- **Hold Time:** Set the length of time to wait, when no audio over the threshold level is detected, before beginning to release the Talk Over mix. The available adjustment range is 0 to 20 seconds.
- **Release Time:** Set the mixer release time, the length of time used fading the microphone’s audio out of the output mix once the mic’s signal level falls below the set threshold. The available adjustment range is 0 to 20 seconds.
- **Reset Talk Over:** Reset all Talk Over settings back to their factory defaults.

4) **Output Mixer:** Set the microphone mixing mode of the unit.

- **Off:** Disable the audio mixer.
- **On:** Enable the audio mixer. Audio from the current source and the microphone will be mixed together.
- **Mic Only:** Output only the microphone audio source. This mode will override all other audio selections.

5) **Volume On Mic Gain:** Set the microphone input’s volume level when the microphone is an active audio source (mixed or unmixed).

6) **Volume On HDMI/HDBT/Analog Out:** Set the volume level for each audio output type.

Note: LPCM 2.0 sources only.

7) **Mute On HDMI/HDBT/Analog Out:** Enable or disable muting the audio of each output type.

8) **HDMI/HDBT/Analog Out Delay:** Set the amount of time (in milliseconds) to the delay the audio output. Primarily used if audio and video seem to be out of sync.

Note: LPCM 2.0 sources only.

9) **Reset Audio:** Reset all audio settings back to their factory defaults.

OSD	
2ND LEVEL	3RD LEVEL
H Position	0~100 (50)
V Position	0~100 (50)
Transparency	0~7 (0)
Timer	OFF
	5s
	10s
	15s
	20s
	25s
	30s
	35s
	40s
	45s
	50s
	55s
	60s

OSD	
2ND LEVEL	3RD LEVEL
Display	Off
	On
	5S
	10s
Reset OSD	

- 1) **H/V Position:** Controls the position of the OSD menu.
- 2) **Transparency:** Set the transparency level of the OSD menu's background. The available range is from Level 0 (fully opaque) to Level 7 (fully transparent).
- 3) **Timer:** Set how long to wait before automatically closing the OSD menu if there is no user activity. The timeout can be set to up to 60 seconds, or disabled completely.
- 4) **Display:** Set the behavior of the OSD informational display. Selecting "5s" or "10s" will show the information display for the specified time after a source or display change. Selecting "Off" will disable the info display. Selecting "On" will always show the info display.
- 5) **Reset OSD:** Reset all OSD settings back to their factory defaults.

ETHERNET			
2ND LEVEL	3RD LEVEL	4TH LEVEL	
IP Mode	Static		
	DHCP		
Telnet Login	OFF		
	On		
Static IP Setting	Static IP		0~255 (192)
			0~255 (168)
			0~255 (1)
			0~255 (50)
	Mask		0~255 (255)
			0~255 (255)
		0~255 (255)	
		0~255 (0)	
	Gate	0~255 (192)	
		0~255 (168)	
		0~255 (1)	
		0~255 (254)	
Reset Static IP			
IP	[Current IP Address]		
MAC	[Unit's MAC Address]		

- 1) **IP Mode:** Set the unit's Ethernet port to Static or DHCP mode. When DHCP mode is selected, all IP address information will be assigned automatically by the local DHCP server. When Static is selected, the IP address, netmask and gateway must be set manually.
- 2) **Telnet Login:** Enable or disable requiring authentication when connecting via Telnet.
- 3) **Static IP Setting:** The unit's static IP address, netmask, and gateway address can be set here.
Note: The unit's default static IP address is 192.168.1.50.
- 4) **Reset Static IP:** Reset all Static IP settings back to their factory defaults.
- 5) **IP/MAC:** Displays the unit's MAC address and current IP address.

EDID	
2ND LEVEL	3RD LEVEL
HDMI 1 EDID	FHD 2CH
	UHD 2ch
	UHD+ 2ch
	User 1
	User 2
	Sink HDMI
	Sink HDBT
	Off
HDMI 2 EDID	[Same options as for HDMI 1]
USB-C EDID	[Same options as for HDMI 1]
Reset EDID	FHD 2ch
	UHD 2ch
	UHD+ 2ch
	User 1
	User 2
	Sink HDMI
	Sink HDBT
	OFF

- 1) **HDMI 1 EDID:** Select the EDID to use with the HDMI 1 input.
- 2) **HDMI 2 EDID:** Select the EDID to use with the HDMI 2 input.
- 3) **USB-C EDID:** Select the EDID to use with the USB-C input.
- 4) **Reset EDID:** Select an EDID to apply to all inputs simultaneously.

SYSTEM	
2ND LEVEL	3RD LEVEL
Remote Control Setup	1: OFF 2: OFF
	1: Off 2: On
	1: On 2: Off
	1: On 2: On
Trigger In 1	HDMI 1
	HDMI 2
	USB-C
	VGA 1
	VGA 2
Trigger In 2	HDMI 1
	HDMI 2
	USB-C
	VGA 1
	VGA 2
Trigger In 3	HDMI 1
	HDMI 2
	USB-C
	VGA 1
	VGA 2
Trigger In 4	HDMI 1
	HDMI 2
	USB-C
	VGA 1
	VGA 2

SYSTEM	
2ND LEVEL	3RD LEVEL
Trigger In 5	HDMI 1
	HDMI 2
	USB-C
	VGA 1
	VGA 2
Reset Trigger In	

- 1) **Remote Control Setup:** Select the custom code pairing that matches the dipswitch settings of the IR remote you wish to use.
Note: The dipswitches on the IR remote are located under the battery compartment cover.
- 2) **Trigger In 1/2/3/4/5:** Set the input to be selected when the associated trigger is activated.
- 3) **Reset Trigger In:** Reset all trigger settings back to their factory defaults.

FACTORY
2ND LEVEL
Reset All
Reset Except Ethernet
FW Update From USB

- 1) **Reset All:** Reset all of the unit's settings back to their factory defaults.
- 2) **Reset Except Ethernet:** Reset all of the unit's settings, except for Ethernet related settings, back to their factory defaults.
- 3) **FW Update From USB:** Provides a way to update the unit's firmware. Insert a USB thumb drive, with a valid firmware file (*.bin format) in the root directory, into the unit's USB service port then select this option. After the update is complete the unit will automatically reboot.

INFORMATION	
2ND LEVEL	3RD LEVEL
VIDEO	
Output Routing	[Current Video Status]
Output Resolution	
HDMI Out HDCP	
HDBT Out HDCP	
Source Resolution	
Source HDCP	
AUDIO	
Output Routing	[Current Audio Status]
Output Mixer	
Mic Type	
HDBT	
Output Status	[Current HDBaseT Status]
IP	[Current IP Address]
Version	[Current Firmware Version]

- 1) **Information:** This screen displays information about the unit's current state, input and output status, as well as the current firmware version.

6.7 WebGUI Control

• Device Discovery

Please obtain the “Device Discovery” software from your authorized dealer and save it in a directory where you can easily find it.

Connect the unit and your PC/Laptop to the same active network and execute the “Device Discovery” software. Click on “Find Devices on Internet” and a list of devices connected to the local network will show up indicating their current IP address.

Note: The unit’s default IP mode is DHCP.

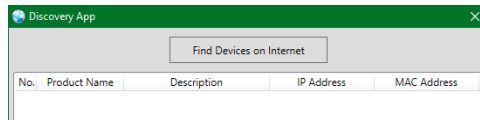

By clicking on one of the listed devices you will be presented with the network details of that particular device.

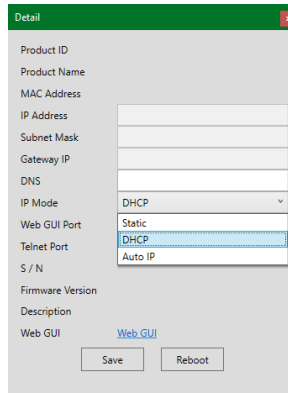

- 1) **IP Mode:** If you choose, you can alter the static IP network settings for the device, or switch the unit into DHCP mode to automatically obtain proper network settings from a local DHCP server. To switch to DHCP mode, please select DHCP from the IP mode drop-down, then click “Save” followed by “Reboot”.
- 2) **WebGUI Hotkey:** Once you are satisfied with the network settings, you may use them to connect via Telnet or WebGUI. The network information window provides a convenient link to launch the WebGUI directly.

- **WebGUI Overview**

After connecting to the WebGUI's address in a web browser, the login screen will appear. Please enter the appropriate user name and password then click "Submit" to log in.

Note: The default user name and password is "admin".



A screenshot of a login form with a light gray background. It contains two input fields: "USER NAME:" and "PASSWORD:". To the right of the "PASSWORD:" field is a "LOGIN" button.

On the left side of the browser you will see the following menu tabs where all primary functions of the unit are controllable via the built in WebGUI. The individual functions will be introduced in the following sections.

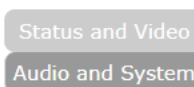

Clicking the "Logout" button in the Authentication section of the "Audio and System" tab will automatically log the currently connected user out of the WebGUI and return to login page.

6.7.1 Status and Video Tab

This tab is divided up into multiple sections (Status, Video, Picture, PC, and EDID) allowing for all functions of the unit to be viewed and controlled directly. If desired, the numerical value for many of the items can be entered directly by typing it in the box above the slider bar. Press “Enter” to accept the newly entered value.

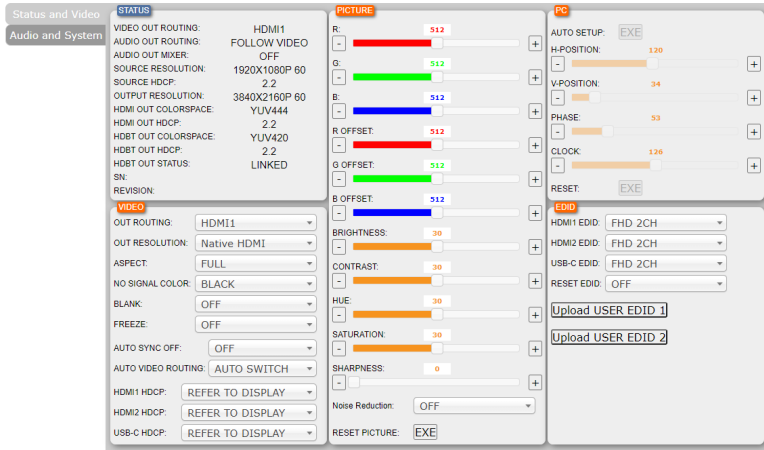

1) **Status:** The section provides detailed information about the current status the video and audio output signals. The unit’s serial number and current firmware version is also displayed here.

2) **Video:** This section provides video routing settings, output resolution selection, and control over the video output signal’s format as well as setting HDCP behavior for the applicable inputs.

- **Out Routing:** Use the dropdown to select the video source to output.

- **Out Resolution:** Use the dropdown to select the output resolution to use. Selecting a “Native” resolution option will make the unit automatically select an output resolution based on the detected EDID of the connected HDBaseT or HDMI display.

Note: 4K@50/60Hz (4:4:4, 8-bit) output resolutions will be automatically color space converted to 4K@50/60 (4:2:0, 8-bit) when output over HDBaseT.

- **Aspect:** Selects the aspect ratio to use when outputting the source. “Full” stretches the source to fill the output resolution, regardless of the original aspect ratio, while “Best Fit” will always attempt to retain the original source’s correct aspect ratio by adding black bars if necessary. “Follow In” centers the source on the screen, without any scaling (1:1 pixel reproduction).

- **No Signal Color:** Use the dropdown to select the full screen color to display when there is no signal. Black, white, blue red, or green may be selected.
 - **Blank:** Enable or disable blanking the video output.
 - **Freeze:** Enable or disable freezing the video output.
 - **Auto Sync Off:** Sets the amount of time to continue outputting sync with the “no signal color” if there is no live source and no operations have been executed on the unit. Setting this to “OFF” forces the unit to always output sync.
 - **Auto Video Routing:** Enable or disable automatically switching to any newly detected source.
 - **HDMI 1~2/USB-C HDCP:** Use each dropdown to select the HDCP behavior for the associated input.
 - **Support Off:** Completely disables support for HDCP on that input.
 - **Refer to Source:** Makes the input port support the same HDCP version as required by the connected source.
 - **Refer to Display:** Makes the input support the HDCP version of the currently connected displays.
- 3) **Picture:** This section provides control over the scaled video output’s color, brightness, contrast, hue, saturation, sharpness and noise reduction.
- **R/G/B Color Gain:** These sliders provide control over the red, green, and blue color gain level of the scaled output.
 - **R/G/B Offset:** These sliders provide control over the red, green, and blue color offset level of the scaled output.
 - **Brightness:** Provides control over the overall brightness of the scaled output image.
 - **Contrast:** Provides control over the overall contrast of the scaled output image.
 - **Hue:** Provides control over the hue shift of the scaled output image.
 - **Saturation:** Provides control over the color saturation level of the scaled output image.
 - **Sharpness:** Provides control over the amount of sharpness processing to apply to the scaled output image.
 - **Noise Reduction:** Provides control over the aggressiveness of the digital noise reduction processing when applied to the scaled output image. Selecting “Off” disables all noise reduction processing.

- **Reset Picture:** Press the “EXE” button to reset all picture settings back to their factory defaults.
- 4) **PC:** This section is only active when a VGA input is selected and provides control over the H/V position, clock, and phase of the VGA signal as well as providing a way to automatically adjust these settings.
- **Auto Setup:** Provides a way to manually activate the auto detection of the VGA source’s signal parameters.
- Note: For best results, a VGA source with a bright image that extends to all 4 edges of the screen should be displayed when this is activated.*
- **H/V Position:** Set the horizontal and vertical position of the current VGA input’s signal.
 - **Phase:** Set the PC phase setting for the current VGA input.
 - **Clock:** Set the PC clock setting for the current VGA input.
 - **Reset:** Press the “EXE” button to reset all PC settings back to their factory defaults.
- 5) **EDID:** This section provides control over the EDID settings of all digital inputs. This unit provides the option of three standard EDIDs, two sink sourced EDIDs and two user uploaded EDIDs that can be assigned to each input port individually.

Note: In some rare cases it is possible for custom or external EDIDs to cause compatibility issues with certain sources. If this happens, it is recommended to switch to one of the 3 default EDIDs for maximum compatibility.

This unit provides the following 3 default EDIDs:

Unit’s default EDIDs	
FHD 2CH	1920×1080p@60Hz (4.95Gbps) & 8-bit color, LPCM 2.0
UHD 2CH	3840×2160p@30Hz (10.2Gbps) & Deep Color (8/10/12-bit), LPCM 2.0
UHD+ 2CH	3840×2160p@60Hz (18Gbps) & Deep Color (8/10/12-bit), LPCM 2.0

Note: In most cases, assigning a new EDID to an input will cause the affected input to briefly blink out while the source adapts to the new information.

- **HDMI 1~2/USB-C EDID:** Use the dropdown to select the EDID to use with the associated input. The new EDID will be used immediately.
- **Reset EDID:** Use the dropdown to select an EDID to apply to ALL digital inputs at the same time. The new EDID will be used by all inputs immediately.
- **Upload User EDID:** To upload a new User EDID, please click the “Upload User EDID” button for the User EDID you would like to change. An EDID Upload window will appear, allowing you to locate and upload the preferred EDID file (*.bin format) from a local PC. Once the correct file has been selected, please click the “Open” button in the window, and the file will be transferred to the unit.

6.7.2 Audio and System Tab

This tab is divided up into multiple sections (Audio, OSD, System, Ethernet, Reset, FWUpdate and Authentication) allowing for all audio and system functions of the unit to be viewed and controlled directly. If desired, the numerical value for many of the items can be entered directly by typing it in the box above the slider bar. Press “Enter” to accept the newly entered value.

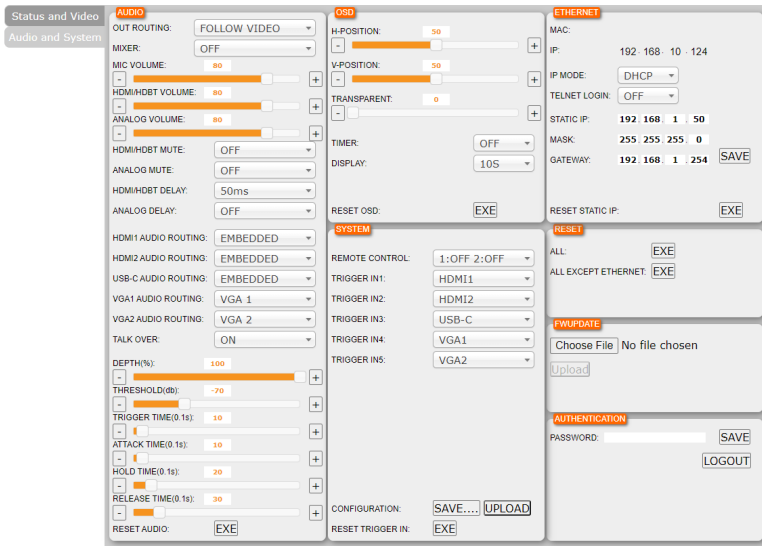

The screenshot displays the 'Audio and System' configuration tab, organized into several functional sections:

- AUDIO:** Includes settings for OUT ROUTING (FOLLOW VIDEO), MIXER (OFF), MIC VOLUME (80), HDMI/DBT VOLUME (80), ANALOG VOLUME (80), HDMI/DBT MUTE (OFF), ANALOG MUTE (OFF), HDMI/DBT DELAY (50ms), ANALOG DELAY (OFF), and routing options for HDMI1, HDMI2, USB-C, VGA1, and VGA2. It also features TALK OVER (ON) and various timing parameters like DEPTH(%) (100), THRESHOLD(db) (-70), TRIGGER TIME(0.1s) (10), ATTACK TIME(0.1s) (10), HOLD TIME(0.1s) (20), and RELEASE TIME(0.1s) (30).
- OSD:** Controls H-POSITION (50), V-POSITION (50), and TRANSPARENT (0) settings, along with TIMER (OFF) and DISPLAY (10S).
- SYSTEM:** Manages REMOTE CONTROL (1:OFF 2:OFF), TRIGGER IN1-5 (HDMI1, HDMI2, USB-C, VGA1, VGA2), and includes buttons for RESET OSD and CONFIGURATION (SAVE, UPLOAD).
- ETHERNET:** Configures MAC, IP (192.168.10.124), IP MODE (DHCP), TELNET LOGIN (OFF), STATIC IP (192.168.1.50), MASK (255.255.255.0), and GATEWAY (192.168.1.254).
- RESET:** Provides buttons for ALL, ALL EXCEPT ETHERNET, and FWUPDATE (Choose File, Upload).
- AUTHENTICATION:** Includes a PASSWORD field and buttons for SAVE and LOGOUT.

- 1) **Audio:** This section provides control over how audio is routed within the unit as well as control over audio mixing, delay, individual output volume and the microphone's gain level.
- **Out Routing:** Use the dropdown to select the audio routing behavior of the unit.
 - **Follow User:** Audio routing will follow the individual audio routing selections made for each source at the bottom of this section.
 - **Follow Video:** All digital sources will use their native embedded audio content. The VGA sources will use the associated VGA 1~2 audio inputs.
 - **Line/VGA 1/VGA 2:** Forces the audio output to always use the selected analog audio source.
 - **Mixer:** Set the microphone mixing mode of the unit.
 - **Off:** Disable the audio mixer.
 - **On:** Enable the audio mixer. Audio from the current source and the microphone will be mixed together.
 - **MIC Only:** Output only the microphone audio source. This mode will override all other audio selections.
 - **Mic Volume:** Sets the microphone input's volume level when the microphone is an active audio source (mixed or unmixed).
 - **HDMI/HDBT Volume:** Set the volume level for the HDMI and HDBaseT audio output.
 - **Analog Volume:** Set the volume level for the line output.
 - **HDMI/HDBT Mute:** Mute or unmute the HDMI and HDBaseT audio output.
 - **Analog Mute:** Mute or unmute the line audio output.
 - **HDMI/HDBT Delay:** Use the dropdown to set the amount of time (in milliseconds) to the delay the audio output. Primarily used if audio and video seem to be out of sync.

Note: LPCM 2.0 sources only.
 - **Analog Delay:** Use the dropdown to set the amount of time (in milliseconds) to the delay the audio output. Primarily used if audio and video seem to be out of sync.
 - **HDMI 1/HDMI2/USB-C/VGA1/VGA2 Audio Routing:** Use each dropdown to set the preferred audio routing to use for each source when "Follow User" is selected.
-

- **Talk Over:** Use the dropdown to enable or disable the use of the unit's Talk Over mode which allows finer control over how the microphone input is handled while mixing sources.

Note: When Talk Over mode is disabled, or the mixer is disabled, the below settings will have no effect.

- **Depth(%):** Sets the amount the primary audio source's volume level will be decreased when the Talk Over feature is triggered. The available adjustment range is 0 to 100%.
 - **Threshold(dB):** Set the microphone's signal detection threshold. The Talk Over will be activated when the microphone's signal is over the threshold and lasting longer than the trigger time. The available adjustment range is -100dB to 0dB.
 - **Trigger Time(0.1s):** Set the length of time a signal must be over the current signal detection threshold in order to trigger the microphone Talk Over function. The available adjustment range is 0 to 20 seconds (in 0.1 second steps).
 - **Attack Time(0.1s):** Set the mixer attack time, the length of time used fading the microphone's audio into the output mix. The available adjustment range is 0 to 20 seconds (in 0.1 second steps).
 - **Hold Time(0.1s):** Set the length of time to wait, when no audio over the threshold level is detected, before beginning to release the Talk Over mix. The available adjustment range is 0 to 20 seconds (in 0.1 second steps).
 - **Release Time(0.1s):** Set the mixer release time, the length of time used fading the microphone's audio out of the output mix once the mic's signal level falls below the set threshold. The available adjustment range is 0 to 20 seconds (in 0.1 second steps).
 - **Reset Audio:** Press the "EXE" button to reset all audio settings back to their factory defaults.
- 2) **OSD:** This section provides controls over the appearance of the unit's informational OSD and OSD menu.
- **H/V Position:** Use the sliders to set the horizontal and vertical position of the OSD menu.
 - **Transparency:** Controls the transparency level of the OSD menu's background. The available range is from Level 0 (fully opaque) to Level 7 (fully transparent).

- **Timer:** Controls how long to wait before automatically closing the OSD menu if there is no user activity. The timeout can be set to up to 60 seconds, or disabled completely.
 - **Display:** Controls the behavior of the OSD informational display. Selecting “5S”, “10S” will show the information display for a short time (5 or 10 seconds) after a source or display change. Selecting “Off” will disable the info display. Selecting “On” will always show the info display.
 - **Reset OSD:** Press the “EXE” button to reset all OSD settings back to their factory defaults.
- 3) **System:** This section provides control over trigger configuration, remote control ID, and saving/restoring the system’s configuration.
- **Remote Control:** Use the dropdown to select the custom code pairing that matches the dipswitch settings of the IR remote you wish to use.
Note: The dipswitches on the IR remote are located under the battery compartment cover.
 - **Trigger In 1~5:** Use each dropdown to set the input to be selected when the associated trigger is activated.
 - **Reset Trigger In:** Press the “EXE” button to reset all trigger settings back to their factory defaults.
 - **Configuration Save:** To export a configuration to your PC, click the “SAVE” button and then select the preferred save location on the local PC. Next, click the “Save” button to complete the file export.
 - **Configuration Upload:** To load a previously saved configuration from your PC, click the “UPLOAD” button to open the file selection window and then select the associated configuration (*.xml format) located on your local PC. After selecting the file, click the “Open” button to import the new configuration. The associated configuration will then be restored.

- 4) **Ethernet:** This section provides a way to change the unit's Ethernet related settings and displays the unit's MAC address as well.
 - **IP Mode:** The unit's IP mode may be switched between Static IP and DHCP. In Static IP mode the IP, netmask and gateway addresses may be manually set. When in DHCP mode, the unit will attempt to connect to a local DHCP server and obtain IP, netmask and gateway addresses automatically. Please press "Save" after making any changes to the IP configuration or mode.

Note: If the IP address is changed then the IP address required for WebGUI/Telnet access will also change accordingly.
 - **Telnet Login:** Enable or disable requiring authentication when connecting via Telnet.
- 5) **Reset:** Press either of the "EXE" buttons to reset the unit's settings back to their factory defaults. Selecting the "All Except Ethernet" button will leave the current Ethernet settings intact after the reset is complete.
- 6) **FW Update:** To update the unit's firmware, click the "Choose File" button to open the file selection window and then select the firmware update file (*.bin format) located on your local PC. After selecting the file, click the "Upload" button to begin the firmware update process. After the upgrade is complete, the unit will reboot automatically.
- 7) **Authentication:** The admin login password may be changed here. Type the preferred new password in the space provided and then press the "Save" button to change it. Clicking the "Logout" button will immediately log you out of the WebGUI and return you to the login page.

Note: The default password is "admin".

6.8 Telnet Control

Before attempting to use Telnet control, please ensure that both the unit and the PC are connected to the same active networks.

Start your preferred Telnet/Console client, or use the built in client provided by most modern computer operating systems. After starting the client, connect by using the current IP address of the unit and port 23 (if the communication port number used by the unit has not been changed previously). This will connect us to the unit we wish to control and commands may now be entered directly.

Note 1: If the IP address of the unit is changed then the IP address required for Telnet access will also change accordingly.

Note 2: This unit defaults to DHCP mode. The current IP address can be verified using the OSD menu or the Device Discovery software. The default communication port is 23.

6.9 Serial and Telnet Commands

COMMAND	
Description and Parameters	
help ↵	Show the full command list.
help N1 ↵	Show details about the specified command. N1 = {Command}
? ↵	Show the full command list.
? N1 ↵	Show details about the specified command. N1 = {Command}
get fw ver ↵	Show the unit's current firmware version.

COMMAND																	
Description and Parameters																	
get command ver ↵	Show the unit's current command version.																
get mac addr ↵	Show the unit's MAC address.																
get model name ↵	Show the unit's model name.																
get model type ↵	<p>Show the unit's product type.</p> <p>Possible response values:</p> <table> <tr> <td>1</td> <td>[Matrix]</td> </tr> <tr> <td>2</td> <td>[Scaler]</td> </tr> <tr> <td>3</td> <td>[Splitter]</td> </tr> <tr> <td>4</td> <td>[Repeater]</td> </tr> <tr> <td>5</td> <td>[Extender]</td> </tr> <tr> <td>6</td> <td>[Transceiver]</td> </tr> <tr> <td>7</td> <td>[Switch]</td> </tr> <tr> <td>8</td> <td>[Controller]</td> </tr> </table>	1	[Matrix]	2	[Scaler]	3	[Splitter]	4	[Repeater]	5	[Extender]	6	[Transceiver]	7	[Switch]	8	[Controller]
1	[Matrix]																
2	[Scaler]																
3	[Splitter]																
4	[Repeater]																
5	[Extender]																
6	[Transceiver]																
7	[Switch]																
8	[Controller]																
set factory default ↵	Reset the unit to the factory defaults.																
set feedback broadcast N1 ↵	<p>Enable or disable the broadcast of console command feedback.</p> <p>Available values for N1:</p> <table> <tr> <td>ON</td> <td>[Enable]</td> </tr> <tr> <td>OFF</td> <td>[Disable]</td> </tr> </table>	ON	[Enable]	OFF	[Disable]												
ON	[Enable]																
OFF	[Disable]																
get feedback broadcast ↵	Show the current console command feedback broadcast state.																
set system reboot ↵	Reboot the unit.																

COMMAND	
Description and Parameters	
set keylock N1 ↵	<p>Enable or disable the front panel key lock.</p> <p>Available values for N1:</p> <p>ON [Locked] OFF [Unlocked]</p>
get keylock ↵	Show the current front panel lock state.
get ip mode ↵	Show the current IP address assignment mode.
get ip addr ↵	Show the unit's current IP address.
get netmask ↵	Show the unit's current netmask.
get gateway ↵	Show the unit's current gateway address.
set static ipaddr N1 ↵	<p>Set the unit's static IP address.</p> <p>N1 = X.X.X.X [X = 0~255, IP address]</p>
get static ipaddr ↵	Show the unit's current static IP address.
set static netmask N1 ↵	<p>Set the unit's static netmask.</p> <p>N1 = X.X.X.X [X = 0~255, netmask]</p>
get static netmask ↵	Show the unit's current static netmask.
set static gateway N1 ↵	<p>Set the unit's static gateway address.</p> <p>N1 = X.X.X.X [X = 0~255, gateway address]</p>

COMMAND	
Description and Parameters	
get static gateway ↵	Show the unit's current static gateway address.
get webgui username ↵	Show the current WebGUI login administrator username.
set webgui password N1 ↵	Set the WebGUI administrator password. N1 = {Password} [ASCII, 16 characters max]
get webgui password ↵	Show the current WebGUI administrator password.
set telnet login N1 ↵	Enable or disable requiring a login to access the unit via Telnet. Available values for N1 : ON [Enabled] OFF [Disabled]
get telnet login ↵	Show the current state of the Telnet login requirement.
get in port number ↵	Show the total number of inputs on the unit.
get out port number ↵	Show the total number of outputs on the unit.
set in N1 name N2 ↵	Set the name of the specified input. Available values for N1 : 1 [HDMI 1] 2 [HDMI 2] 3 [USB-C] 4 [VGA 1] 5 [VGA 2] N2 = {Name} [ASCII, 16 characters max]

COMMAND	
Description and Parameters	
get in N1 name ↵	Show the current name of the specified input.
set out A name N1 ↵	Set the name of the HDMI/HDBaseT output. N1={Name} [ASCII, 16 characters max]
get out A name ↵	Show the name of the HDMI/HDBaseT output.
set out A route N1 ↵	Route the specified input to the HDMI/HDBaseT output. Available values for N1: 1 [HDMI 1] 2 [HDMI 2] 3 [USB-C] 4 [VGA 1] 5 [VGA 2]
get out A route ↵	Show the current input routed to the HDMI/HDBaseT output.
set out auto mode N1 ↵	Set the auto switching behavior of the unit. Available values for N1: 0 [Auto switch mode disabled] 1 [Auto switch mode enabled]
get out auto mode ↵	Set the auto switching/scanning behavior of the unit.

COMMAND**Description and Parameters****get in N1 timing**↵

Show the index number of the current resolution detected on the specified input.

Available values for **N1**:

1	[HDMI 1]
2	[HDMI 2]
3	[USB-C]
4	[VGA 1]
5	[VGA 2]

get in N1 timing string↵

Show the index number and description of the current resolution detected on the specified input.

Available values for **N1**:

1	[HDMI 1]
2	[HDMI 2]
3	[USB-C]
4	[VGA 1]
5	[VGA 2]

get out N1 color space↵

Show the color space format currently used by the specified output.

Available values for **N1**:

A	[HDMI output]
B	[HDBaseT output]

Possible response values:

0	[Unknown]
1	[RGB]
2	[YUV 4:2:2]
3	[YUV 4:4:4]
4	[YUV 4:2:0]

COMMAND

Description and Parameters

set out A timing N1↵

Set the output resolution to use for the HDMI/HDBaseT output.

Available values for N1:

0	[Native HDMI]
1	[Native HDBaseT]
2	[640×480@60Hz]
3	[800×600@60Hz]
4	[1024×768@60Hz]
5	[1280×768@60Hz]
6	[1280×800@60Hz]
7	[1280×1024@60Hz]
8	[1360×768@60Hz]
9	[1400×1050@60Hz]
10	[1440×900@60Hz]
11	[1600×1200@60Hz]
12	[1680×1050@60Hz]
13	[1920×1200@60Hz RB]
14	[2560×1600@60Hz RB]
15	[1920×1080@60Hz]
16	[1280×720@60Hz]
17	[2048×1080@50Hz]
18	[2048×1080p@60Hz]
19	[2560×1440@60Hz RB]
20	[720×480p@60Hz]
21	[1280×720p@60Hz]
22	[1920×1080p@60Hz]
23	[720×576p@50Hz]
24	[1280×720p@50Hz]
25	[1920×1080p@50Hz]
26	[1920×1080p@24Hz]
27	[1920×1080p@25Hz]
28	[1920×1080p@30Hz]
29	[2560×1080p@50Hz]
30	[2560×1080p@60Hz]
31	[3840×2160p@24Hz]
32	[3840×2160p@25Hz]
33	[3840×2160p@30Hz]
34	[3840×2160p@50Hz]
35	[3840×2160p@60Hz]
36	[4096×2160p@24Hz]

COMMAND	
Description and Parameters	
37	[4096×2160p@25Hz]
38	[4096×2160p@30Hz]
39	[4096×2160p@50Hz]
40	[4096×2160p@60Hz]
get out A timing ↵↵	
Show the current resolution used by the HDMI/HDBaseT output.	
get out N1 timing string ↵↵	
Show the description string of the current resolution used by the HDMI/HDBaseT output.	
get out timing list ↵↵	
List all available output resolutions with their local index numbers.	
set out A contrast N1 ↵↵	
Set the contrast level of the HDMI/HDBaseT output.	
N1 = 0~60	[Contrast level]
get out A contrast ↵↵	
Show the current contrast level of the HDMI/HDBaseT output.	
set out A brightness N1 ↵↵	
Set the brightness level of the HDMI/HDBaseT output.	
N1 = 0~60	[Brightness level]
get out A brightness ↵↵	
Show the current brightness level of the HDMI/HDBaseT output.	
set out A saturation N1 ↵↵	
Set the saturation level of the HDMI/HDBaseT output.	
N1 = 0~60	[Saturation level]
get out A saturation ↵↵	
Show the current saturation level of the HDMI/HDBaseT output.	

COMMAND											
Description and Parameters											
set out A hue N1	<p>Set the hue value of the HDMI/HDBaseT output.</p> <p>N1 = 0~60 [Hue value]</p>										
get out A hue	<p>Show the current hue value of the HDMI/HDBaseT output.</p>										
set out A sharpness N1	<p>Set the sharpness level of the HDMI/HDBaseT output.</p> <p>N1 = 0~60 [Sharpness level]</p>										
get out A sharpness	<p>Show the current sharpness level of the HDMI/HDBaseT output.</p>										
set out A nr N1	<p>Set the amount of noise reduction to apply to the HDMI/HDBaseT output's source.</p> <p>Available values for N1:</p> <table border="0"> <tr> <td>0</td> <td>[Off]</td> </tr> <tr> <td>1</td> <td>[Low]</td> </tr> <tr> <td>2</td> <td>[Middle]</td> </tr> <tr> <td>3</td> <td>[High]</td> </tr> <tr> <td>4</td> <td>[Auto]</td> </tr> </table>	0	[Off]	1	[Low]	2	[Middle]	3	[High]	4	[Auto]
0	[Off]										
1	[Low]										
2	[Middle]										
3	[High]										
4	[Auto]										
get out A nr	<p>Show the current amount of noise reduction applied to the HDMI/HDBaseT output's source.</p>										
get out nr list	<p>List all available noise reduction processing options.</p>										

COMMAND	
Description and Parameters	
set out A aspect ratio N1 ←	
Set the aspect ratio of the video shown on the HDMI/HDBaseT output.	
Available values for N1 :	
1	[Over Scan]
2	[Full]
3	[Best Fit]
4	[Pan Scan]
5	[Letterbox]
6	[Under 2]
7	[Under 1]
8	[Follow In]
get out A aspect ratio ←	
Show the currently set aspect ratio for the video shown on the HDMI/HDBaseT output.	
get out aspect ratio list ←	
List all available aspect ratio options.	
set out A auto sync off N1 ←	
Enable or disable the Auto Sync Off function on the HDMI/HDBaseT output and set the timeout length.	
Available values for N1 :	
0	[Disabled]
1	[30 seconds]
2	[60 seconds]
3	[3 minutes]
4	[5 minutes]
5	[10 minutes]
get out A auto sync off ←	
Show the current Auto Sync Off settings for the HDMI/HDBaseT output.	
set out A r gain N1 ←	
Set the HDMI/HDBaseT output's red gain level.	
N1 = 0~1023	[Red gain level]

COMMAND	
Description and Parameters	
get out A r gain ↵	Show the HDMI/HDBaseT output's current red gain level.
set out A g gain N1 ↵	Set the HDMI/HDBaseT output's green gain level. N1 = 0~1023 [Green gain level]
get out A g gain ↵	Show the HDMI/HDBaseT output's current green gain level.
set out A b gain N1 ↵	Set the HDMI/HDBaseT output's blue gain level. N1 = 0~1023 [Blue gain level]
get out A b gain ↵	Show the HDMI/HDBaseT output's current blue gain level.
set out A r offset N1 ↵	Set the HDMI/HDBaseT output's red offset level. N1 = 0~1023 [Red offset level]
get out A r offset ↵	Show the HDMI/HDBaseT output's current red offset level.
set out A g offset N1 ↵	Set the HDMI/HDBaseT output's green offset level. N1 = 0~1023 [Green offset level]
get out A g offset ↵	Show the HDMI/HDBaseT output's current green offset level.
set out A b offset N1 ↵	Set the HDMI/HDBaseT output's blue offset level. N1 = 0~1023 [Blue offset level]
get out A b offset ↵	Show the HDMI/HDBaseT output's current blue offset level.

COMMAND					
Description and Parameters					
set in N1 phase N2↵	<p>Set the PC phase value for the specified input (VGA inputs only).</p> <p>Available values for N1:</p> <table> <tr> <td>4</td> <td>[VGA 1]</td> </tr> <tr> <td>5</td> <td>[VGA 2]</td> </tr> </table> <p>N2 = 0~250 [PC phase value]</p>	4	[VGA 1]	5	[VGA 2]
4	[VGA 1]				
5	[VGA 2]				
get in N1 phase↵	<p>Show the current PC phase value for the specified input (VGA inputs only).</p> <p>Available values for N1:</p> <table> <tr> <td>4</td> <td>[VGA 1]</td> </tr> <tr> <td>5</td> <td>[VGA 2]</td> </tr> </table>	4	[VGA 1]	5	[VGA 2]
4	[VGA 1]				
5	[VGA 2]				
set in N1 clock N2↵	<p>Set the PC clock value for the specified input (VGA inputs only).</p> <p>Available values for N1:</p> <table> <tr> <td>4</td> <td>[VGA 1]</td> </tr> <tr> <td>5</td> <td>[VGA 2]</td> </tr> </table> <p>N2 = 0~250 [PC clock value]</p>	4	[VGA 1]	5	[VGA 2]
4	[VGA 1]				
5	[VGA 2]				
get in N1 clock↵	<p>Show the current PC clock value for the specified input (VGA inputs only).</p> <p>Available values for N1:</p> <table> <tr> <td>4</td> <td>[VGA 1]</td> </tr> <tr> <td>5</td> <td>[VGA 2]</td> </tr> </table>	4	[VGA 1]	5	[VGA 2]
4	[VGA 1]				
5	[VGA 2]				
set in N1 hposition N2↵	<p>Set the PC horizontal position for the specified input (VGA inputs only).</p> <p>Available values for N1:</p> <table> <tr> <td>4</td> <td>[VGA 1]</td> </tr> <tr> <td>5</td> <td>[VGA 2]</td> </tr> </table> <p>N2 = 0~250 [Horizontal position]</p>	4	[VGA 1]	5	[VGA 2]
4	[VGA 1]				
5	[VGA 2]				

COMMAND	
Description and Parameters	
get in N1 hposition ↵	
Show the current PC horizontal position for the specified input (VGA inputs only).	
Available values for N1 :	
4	[VGA 1]
5	[VGA 2]
set in N1 vposition N2 ↵	
Set the PC vertical position for the specified input (VGA inputs only).	
Available values for N1 :	
4	[VGA 1]
5	[VGA 2]
N2 = 0~250	[Vertical position]
get in N1 vposition ↵	
Show the current PC vertical position for the specified input (VGA inputs only).	
Available values for N1 :	
4	[VGA 1]
5	[VGA 2]
get in N1 correct timing list ↵	
List the available “correct timing” options supported by the specified VGA input.	
Available values for N1 :	
4	[VGA 1]
5	[VGA 2]

COMMAND	
Description and Parameters	
set in N1 correct timing N2 ↵	
Force the specified VGA input to detect the incoming signal (which shares the same pixel clock) as the specified valid timing.	
Available values for N1 :	
4	[VGA 1]
5	[VGA 2]
Available values for N2 :	
0	[1280×960@60Hz]
1	[1600×900@60Hz RB]
get in N1 correct timing ↵	
Show the currently selected correct timing choice in use by the specified VGA input.	
Available values for N1 :	
4	[VGA 1]
5	[VGA 2]
set vga auto adjust mode N1 ↵	
Enable or disable the VGA input auto adjust function.	
Available values for N1 :	
ON	[Enable]
OFF	[Disable]
get vga auto adjust mode ↵	
Show the current state of the VGA input auto adjust function.	
set out A freeze N1 ↵	
Enable or disable the HDMI/HDBaseT output's freeze function.	
Available values for N1 :	
ON	[Enable]
OFF	[Disable]
get out A freeze ↵	
Show the current state of the HDMI/HDBaseT output's freeze function.	

COMMAND	
Description and Parameters	
set out A blank N1 ←	
Enable or disable the HDMI/HDBaseT output's video blanking function.	
Available values for N1 :	
ON	[Enable]
OFF	[Disable]
get out A blank ←	
Show the current state of the HDMI/HDBaseT output's blanking function.	
set out A osd timeout N1 ←	
Set the OSD menu's timeout value for the HDMI/HDBaseT output (in seconds).	
Available values for N1 :	
0	[Timeout disabled]
5~60	[Timeout in seconds]
get out A osd timeout ←	
Show the current OSD menu timeout value for the HDMI/HDBaseT output.	
set out A osd info display N1 ←	
Enable, disable, or set the info OSD's timeout value for the HDMI/HDBaseT output.	
Available values for N1 :	
0	[Always off]
1	[Always on]
2	[5 seconds]
3	[10 seconds]
get out A osd info display ←	
Show the current info OSD setting for the HDMI/HDBaseT output.	
set out A osd vposition N1 ←	
Set the vertical position of the OSD menu on the HDMI/HDBaseT output.	
N1 = 0~100	[Vertical position]

COMMAND	
Description and Parameters	
get out A osd vposition ↵	
Show the current vertical position of the OSD menu on the HDMI/HDBaseT output.	
set out A osd hposition N1 ↵	
Set the horizontal position of the OSD menu on the HDMI/HDBaseT output.	
N1 = 0~100	[Horizontal position]
get out A osd hposition ↵	
Show the current horizontal position of the OSD menu on the HDMI/HDBaseT output.	
set out A osd transparency level N1 ↵	
Set the transparency level of the OSD menu on the HDMI/HDBaseT output.	
N1 = 0~7	[Transparency level]
get out A osd transparency level ↵	
Show the current transparency level of the OSD menu on the HDMI/HDBaseT output.	
set audio out N1 mute N2 ↵	
Enable or disable muting the specified audio output.	
Available values for N1 :	
A	[HDMI/HDBaseT output]
B	[Line out]
Available values for N2 :	
ON	[Mute]
OFF	[Unmute]
get audio out N1 mute ↵	
Show the current mute state of the specified output.	
Available values for N1 :	
A	[HDMI/HDBaseT output]
B	[Line out]

COMMAND	
Description and Parameters	
set audio out A route N1 ↵	
Route the specified audio input to all audio outputs.	
Available values for N1 :	
1	[Follow user]
2	[Follow video]
3	[VGA 1]
4	[VGA 2]
5	[Line in]
get audio out A route ↵	
Show the current audio input routed to all audio outputs.	
set audio out N1 volume N2 ↵	
Set the volume level of the specified output's audio.	
Available values for N1 :	
A	[HDMI/HDBaseT output]
B	[Line out]
N2 = 0~100	[Volume level]
get audio out N1 volume ↵	
Show the current volume level of the specified output's audio.	
Available values for N1 :	
A	[HDMI/HDBaseT output]
B	[Line out]
set audio out N1 volume up ↵	
Increase the volume level of the specified output's audio by 1 unit.	
Available values for N1 :	
A	[HDMI/HDBaseT output]
B	[Line out]
set audio output N1 volume down ↵	
Decrease the volume level of the specified output's audio by 1 unit.	
Available values for N1 :	
A	[HDMI/HDBaseT output]
B	[Line out]

COMMAND					
Description and Parameters					
set audio out N1 name N2↵	<p>Set the name for the specified output's audio.</p> <p>Available values for N1:</p> <table> <tr> <td>A</td> <td>[HDMI/HDBaseT output]</td> </tr> <tr> <td>B</td> <td>[Line out]</td> </tr> </table> <p>N2 = {Name} [ASCII, 16 characters max]</p>	A	[HDMI/HDBaseT output]	B	[Line out]
A	[HDMI/HDBaseT output]				
B	[Line out]				
get audio out N1 name↵	<p>Show the current name for the specified output's audio.</p> <p>Available values for N1:</p> <table> <tr> <td>A</td> <td>[HDMI/HDBaseT output]</td> </tr> <tr> <td>B</td> <td>[Line out]</td> </tr> </table>	A	[HDMI/HDBaseT output]	B	[Line out]
A	[HDMI/HDBaseT output]				
B	[Line out]				
set audio out N1 delay N2↵	<p>Set the audio delay for the specified output's audio.</p> <p>Available values for N1:</p> <table> <tr> <td>A</td> <td>[HDMI/HDBaseT output]</td> </tr> <tr> <td>B</td> <td>[Line out]</td> </tr> </table> <p>N2 = 0~200 [Audio delay in milliseconds]</p> <p><i>Note: Value must be entered as a multiple of 10.</i></p>	A	[HDMI/HDBaseT output]	B	[Line out]
A	[HDMI/HDBaseT output]				
B	[Line out]				
get audio out N1 delay↵	<p>Show the current audio delay for the specified output's audio.</p> <p>Available values for N1:</p> <table> <tr> <td>A</td> <td>[HDMI/HDBaseT output]</td> </tr> <tr> <td>B</td> <td>[Line out]</td> </tr> </table>	A	[HDMI/HDBaseT output]	B	[Line out]
A	[HDMI/HDBaseT output]				
B	[Line out]				
get audio in type list↵	<p>List all available audio input sources.</p>				
get audio out type list↵	<p>List all available audio output destinations.</p>				

COMMAND					
Description and Parameters					
set audio mixer N1 ↵	<p>Enable or disable the unit's audio mixer function.</p> <p>Available values for N1:</p> <table> <tr> <td>ON</td> <td>[Enable]</td> </tr> <tr> <td>OFF</td> <td>[Disable]</td> </tr> </table>	ON	[Enable]	OFF	[Disable]
ON	[Enable]				
OFF	[Disable]				
get audio mixer ↵	<p>Show the current state of the unit's audio mixer.</p>				
set audio mixer in 1 volume N2 ↵	<p>Set the audio mixer's input volume level for the mic audio source.</p> <p>N2 = 0~100 [Mic volume level]</p>				
get audio mixer in 1 volume ↵	<p>Show the audio mixer's current input volume level for the mic audio source.</p>				
set audio out A talkover N1 ↵	<p>Set the talkover function's state for all audio outputs.</p> <p>Available values for N1:</p> <table> <tr> <td>ON</td> <td>[Enable]</td> </tr> <tr> <td>OFF</td> <td>[Disable]</td> </tr> </table>	ON	[Enable]	OFF	[Disable]
ON	[Enable]				
OFF	[Disable]				
get audio out A talkover ↵	<p>Show the current state of the talkover function on all audio outputs.</p>				
set audio out A talkover trigger time N1 ↵	<p>Set the talkover function's trigger time value for all audio outputs.</p> <p>N1 = 0~200 [Trigger time in 0.1 second units]</p>				
get audio out A talkover trigger time ↵	<p>Show the current talkover trigger time value for all audio outputs.</p>				
set audio out A talkover attack time N1 ↵	<p>Set the talkover function's attack time value for all audio outputs.</p> <p>N1 = 0~200 [Attack time in 0.1 second units]</p>				

COMMAND	
Description and Parameters	
get audio out A talkover attack time ↵	Show the current talkover attack time value for all audio outputs.
set audio out A talkover hold time N1 ↵	Set the talkover function's hold time value for all audio outputs. N1 = 0~200 [Hold time in 0.1 second units]
get audio out A talkover hold time ↵	Show the current talkover hold time value for all audio outputs.
set audio out A talkover release time N1 ↵	Set the talkover function's release time value for all audio outputs. N1 = 0~200 [Release time in 0.1 second units]
get audio out A talkover release time ↵	Show the current talkover release time value for all audio outputs.
set audio out A talkover depth N1 ↵	Set the talkover function's depth value for all audio outputs. N1 = 0~100 [Depth in percentage]
get audio out A talkover depth ↵	Show the current talkover depth value for all audio outputs.
set audio out A talkover threshold N1 ↵	Set the talkover function's threshold value for all audio outputs. N1 = -100~0 [Threshold in dB]
get audio out A talkover threshold ↵	Show the current talkover threshold value for all audio outputs.

COMMAND	
Description and Parameters	
set in N1 edid N2 ↵	
Set the EDID to use on the specified input.	
Available values for N1 :	
1	[HDMI 1]
2	[HDMI 2]
3	[USB-C]
Available values for N2 :	
1	[FHD, 2 Channel]
2	[UHD, 2 Channel]
3	[UHD+, 2 Channel]
4	[User EDID 1]
5	[User EDID 2]
6	[HDMI output's EDID]
7	[HDBaseT output's EDID]
get in N1 edid ↵	
Show the EDID currently being used on the specified input.	
Available values for N1 :	
1	[HDMI 1]
2	[HDMI 2]
3	[USB-C]
get in edid list ↵	
List all available EDID selections.	
set edid N1 name N2 ↵	
Set the name for the specified User EDID.	
N1 = 1~2	[User EDID number]
N2 = {Name}	[ASCII, 16 characters max]
<i>Note: Only User EDIDs may be renamed.</i>	
get edid N1 name ↵	
Show the name for the specified User EDID.	
N1 = 1~2	[User EDID number]

COMMAND	
Description and Parameters	
set user N1 edid data N2↵	<p>Upload a new EDID (in hex format) for use as the specified User EDID.</p> <p>N1 = 1~2 [User EDID number]</p> <p>N2 = {EDID data} [Comma delimited hex pairs]</p>
get user N1 edid data↵	<p>Show the current contents of the specified User EDID as hex data.</p> <p>N1 = 1~2 [User EDID number]</p>
get sink N1 edid data↵	<p>Show the EDID from the display connected to the specified output as hex data.</p> <p>Available values for N1:</p> <p>A [HDMI output]</p> <p>B [HDBaseT output]</p>
get in N1 edid data↵	<p>Show the EDID currently used by the specified input as hex data.</p> <p>Available values for N1:</p> <p>1 [HDMI 1]</p> <p>2 [HDMI 2]</p> <p>3 [USB-C]</p>
get all in edid list↵	<p>List the EDIDs assigned to all inputs.</p>
get internal N1 edid data↵	<p>Show the specified Internal EDID as hex data.</p> <p>Available values for N1:</p> <p>1 [FHD, 2 Channel]</p> <p>2 [UHD, 2 Channel]</p> <p>3 [UHD+, 2 Channel]</p>

COMMAND	
Description and Parameters	
set in N1 hdcp mode N2↵	
Set the HDCP behavior of the specified input.	
Available values for N1 :	
1	[HDMI 1]
2	[HDMI 2]
3	[USB-C]
Available values for N2 :	
0	[HDCP Support disabled]
1	[Refer to source]
2	[Refer to display]
get in N1 hdcp mode↵	
Show the current HDCP behavior used by the specified input.	
Available values for N1 :	
1	[HDMI 1]
2	[HDMI 2]
3	[USB-C]
Possible response values:	
0	[HDCP Support Off]
1	[Refer to Source]
2	[Refer to Display]

Note: Commands will not be executed unless followed by a carriage return. Commands are not case-sensitive.

7. CONNECTION DIAGRAM

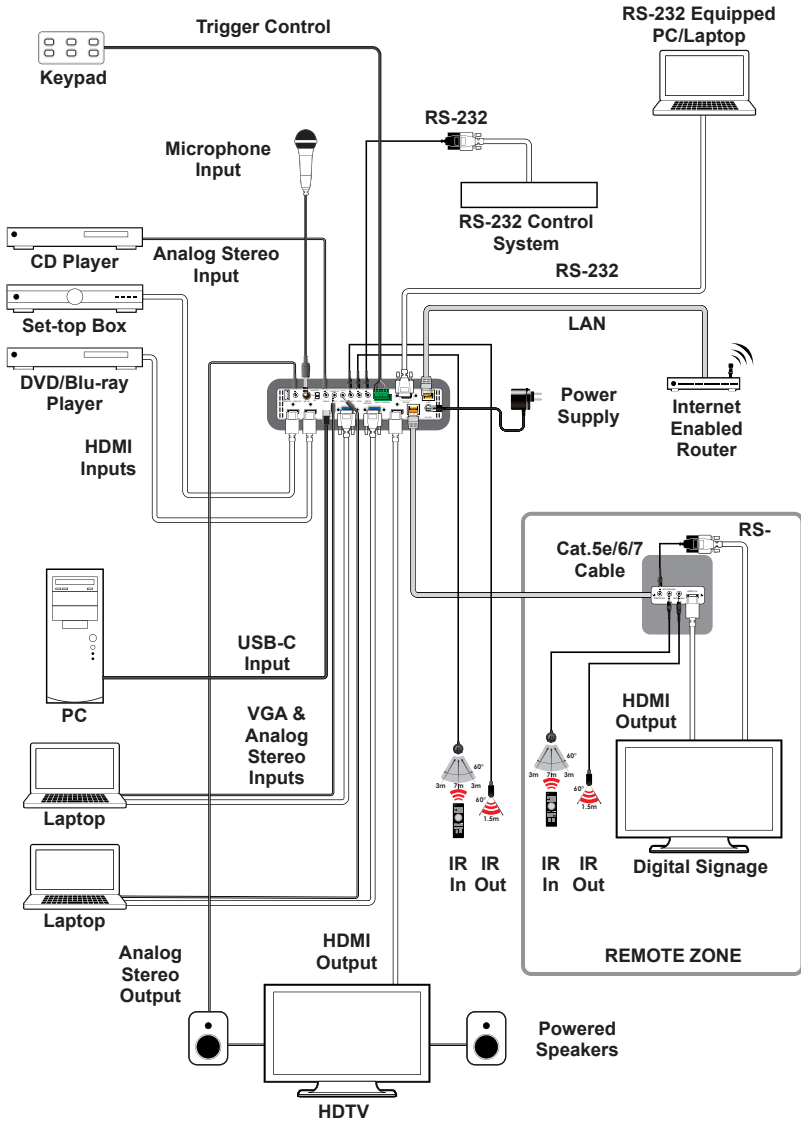

8. SPECIFICATIONS

8.1 Technical Specifications

HDMI Bandwidth	18Gbps
USB-C Bandwidth	21.6Gbps
VGA Bandwidth	165MHz
HDBaseT Bandwidth	10.2Gbps
Input Ports	2×HDMI (Type-A) 1×USB (Type-C) 2×VGA (HD-15) 3×Stereo Audio (3.5mm) 1×Mic In (6.5mm)
Output Ports	1×HDMI (Type-A) 1×HDBaseT (RJ-45) 1×Line Out (3.5mm)
Pass-through Ports	1×IR Extender (3.5mm) 1×IR Blaster (3.5mm) 1×RS-232 (3.5mm)
Control Ports	1×RS-232 (DE-9) 1×IP Control (RJ-45) 1×Trigger (6-pin Terminal Block)
Service Port	1×USB 2.0 (Type-A)
IR Frequency	30 ~ 50kHz (30 ~ 60kHz under ideal conditions)
Baud Rate	19200 (Control)/Up to 115200 (Bypass)
Power Supply	24V/5A DC (US/EU standards, CE/FCC/UL certified)
ESD Protection (HBM)	±8kV (Air Discharge) ±4kV (Contact Discharge)
Dimensions (W×H×D)	219mm×43mm×156mm [Case Only] 219mm×51mm×162mm [All Inclusive]

Weight	1308g
Chassis Material	Metal (Steel)
Chassis Color	Black
Operating Temperature	0°C – 40°C/32°F – 104°F
Storage Temperature	-20°C – 60°C/-4°F – 140°F
Relative Humidity	20 – 90% RH (Non-condensing)
Power Consumption	102W

8.2 Video Specifications

Supported Resolutions (Hz)	Input			Output	
	HDMI	USBC	VGA	HDMI	HDBT
720×400p@70/85	✓	✓	✓	×	×
640×480p@60/72/75/85	✓	✓	✓	60	60
720×480i@60	✓	×	×	×	×
720×480p@60	✓	✓	✓	✓	✓
720×576i@50	✓	×	×	×	×
720×576p@50	✓	✓	✓	✓	✓
800×600p@56/60/72/75/85	✓	✓	✓	60	60
848×480p@60	✓	✓	✓	×	×
1024×768p@60/70/75/85	✓	✓	✓	60	60
1152×864p@75	✓	✓	✓	×	×
1280×720p@50/60	✓	✓	✓	✓	✓
1280×768p@60/75/85	✓	✓	✓	60	60
1280×800p@60/75/85	✓	×	✓	60	60
1280×960p@60/85	✓	✓	✓	×	×
1280×1024p@60/75/85	✓	✓	✓	60	60
1360×768p@60	✓	✓	✓	✓	✓

Supported Resolutions (Hz)	Input			Output	
	HDMI	USBC	VGA	HDMI	HDBT
1366×768p@60	✓	✓	✓	x	x
1400×1050p@60	✓	✓	✓	✓	✓
1440×900p@60/75	✓	✓	✓	60	60
1600×900p@60RB	✓	✓	✓	x	x
1600×1200p@60	✓	✓	✓	✓	✓
1680×1050p@60	✓	✓	✓	✓	✓
1920×1080i@50/60	✓	x	x	x	x
1920×1080p@24/25/30	✓	✓	✓	✓	✓
1920×1080p@50/60	✓	✓	✓	✓	✓
1920×1200p@60RB	✓	✓	✓	✓	✓
2560×1440p@60RB	✓	✓	x	✓	✓
2560×1600p@60RB	✓	✓	x	x	x
2048×1080p@24/25/30	✓	✓	x	x	x
2048×1080p@50/60	✓	✓	x	x	x
3840×2160p@24/25/30	✓	✓	x	✓	✓
3840×2160p@50/60 (4:2:0)	✓	x	x	✓	✓
3840×2160p@24, HDR10	x	x	x	x	x
3840×2160p@50/60 (4:2:0), HDR10	x	x	x	x	x
3840×2160p@50/60	✓	✓	x	✓	x
4096×2160p@24/25/30	✓	✓	x	✓	✓
4096×2160p@50/60 (4:2:0)	✓	x	x	✓	✓
4096×2160p@24, HDR10	x	x	x	x	x
4096×2160p@50/60 (4:2:0), HDR10	x	x	x	x	x
4096×2160p@50/60	✓	✓	x	✓	x

8.3 Audio Specifications

8.3.1 Digital Audio

HDMI Input / Output	
LPCM	
Max Channels	2 Channels
Sampling Rate (kHz)	48
Bitstream	
Supported Formats	None
HDBaseT Output	
LPCM	
Max Channels	2 Channels
Sampling Rate (kHz)	48
Bitstream	
Supported Formats	None

8.3.2 Analog Audio

Analog Input	
Max Audio Level	2Vrms
Impedance	48k Ω
Type	Unbalanced

Analog Output	
Max Audio Level	2Vrms
THD+N	< -85dB@0dBFS 1kHz (A-wt)
SNR	> 102dB@0dBFS
Frequency Response	< \pm 1dB@20Hz~20kHz
Crosstalk	< -63dB@10kHz
Impedance	470 Ω
Type	Unbalanced

8.4 Cable Specifications

Cable Length	1080p		4K30	4K60
	8-bit	12-bit	(4:4:4) 8-bit	(4:4:4) 8-bit
High Speed HDMI Cable				
HDMI Input	15m	10m	5m	3m
HDMI Output	15m	10m	5m	3m
USB-C Cable				
USB-C Input	2m			1m
VGA Cable				
VGA Input	2m		x	
Ethernet Cable				
Cat.5e/6	100m		70m	x
Cat.6A/7	100m		100m	x

Bandwidth Category Examples:

- **1080p (FHD Video)**
 - Up to 1080p@60Hz, 12-bit color
 - Data rates lower than 5.3Gbps or below 225MHz TMDS clock
- **4K30 (UHD Video)**
 - 4K@24/25/30Hz & 4K@50/60Hz (4:2:0), 8-bit color
 - Data rates higher than 5.3Gbps or above 225MHz TMDS clock but below 10.2Gbps
- **4K60 (UHD⁺ Video)**
 - 4K@50/60Hz (4:4:4, 8-bit)
 - 4K@50/60Hz (4:2:0, 10-bit HDR)
 - Data rates higher than 10.2Gbps

8.5 HDBaseT Features

HDBaseT Feature Set	Transmitter
Video & Audio Extension	Supported
LAN Extension	Supported
Send power to Receiver	Supported (PoH)
Accept power from Receiver	Unsupported
IR Extension	Supported
RS-232 Extension	Supported
USB 2.0 Extension	Unsupported

9. ACRONYMS

ACRONYM	COMPLETE TERM
ADC	Analog-to-Digital Converter
ASCII	American Standard Code for Information Interchange
Cat.5e	Enhanced Category 5 cable
Cat.6	Category 6 cable
Cat.6A	Augmented Category 6 cable
Cat.7	Category 7 cable
CLI	Command-Line Interface
DAC	Digital-to-Analog Converter
dB	Decibel
DHCP	Dynamic Host Configuration Protocol
DP	DisplayPort
DVI	Digital Visual Interface
EDID	Extended Display Identification Data
GbE	Gigabit Ethernet
Gbps	Gigabits per second
GUI	Graphical User Interface
HDBT	HDBaseT
HDCP	High-bandwidth Digital Content Protection
HDMI	High-Definition Multimedia Interface
HDR	High Dynamic Range
IP	Internet Protocol
IR	Infrared
kHz	Kilohertz
LAN	Local Area Network
LED	Light-Emitting Diode
LPCM	Linear Pulse-Code Modulation
MAC	Media Access Control
MHz	Megahertz

ACRONYM	COMPLETE TERM
OSD	On-Screen Display
PD	Powered Device
PoH	Power over HDBaseT
PSE	Power Sourcing Equipment
SNR	Signal-to-Noise Ratio
TCP	Transmission Control Protocol
THD+N	Total Harmonic Distortion plus Noise
TMDS	Transition-Minimized Differential Signaling
4K UHD	4K Ultra-High-Definition (10.2Gbps max)
4K UHD*	4K Ultra-High-Definition (18Gbps max)
USB	Universal Serial Bus
VGA	Video Graphics Array
WUXGA (RB)	Widescreen Ultra Extended Graphics Array (Reduced Blanking)
XGA	Extended Graphics Array
Ω	Ohm



CYPRESS TECHNOLOGY CO., LTD.
www.cypress.com.tw
